

42CE RightSight C18 Photoelectric Sensors

Catalog Numbers 42CE-D2MNA1-A2, 42CE-D2MNA1-D4, 42CE-D2MPA1-A2, 42CE-D2MPA1-D4, 42CE-B2MNB1-A2, 42CE-B2MNB1-D4, 42CE-B2MPB1-A2, 42CE-B2MPB1-D4, 42CE-B2MNB2-A2, 42CE-B2MNB2-D4, 42CE-B2MPB2-A2, 42CE-B2MPB2-D4, 42CE-B2MNA3-A2, 42CE-B2MNA3-D4, 42CE-B2MPA3-A2, 42CE-B2MPA3-D4, 42CE-N2MNA1-A2, 42CE-N2MNA1-D4, 42CE-N2MPA1-A2, 42CE-N2MPA1-D4, 42CE-P2MNB1-A2, 42CE-P2MNB1-D4, 42CE-P2MPB1-A2, 42CE-P2MPB1-D4, 42CE-P2MNA1-A2, 42CE-P2MNA1-D4, 42CE-P2MPA1-A2, 42CE-P2MPA1-D4, 42CE-E2EZB1-A2, 42CE-E2EZB1-D4, 42CE-R2MNB1-A2, 42CE-R2MNB1-D4, 42CE-R2MPB1-A2, 42CE-R2MPB1-D4

Topic	Page
Summary of Changes	1
Overview	1
Specifications	2
Product Selection	2
Status Indicators and User Interface	3
Wiring	3
Typical Response Curves	4
Approximate Dimensions	7

Summary of Changes

This publication contains the following new or updated information. This list includes substantive updates only and is not intended to reflect all changes.

Topic	Page
Updated Figure 1	3
Updated Figure 19	7

Overview

The Allen-Bradley® RightSight™ C18 family offers a wide range of sensing modes and an adjustment knob that simplifies sensitivity adjustment for maximum application flexibility.

The RightSight sensor offers an industry standard 18 mm (0.71 in.) cylindrical housing ideal for compact housing installations.

Features

- Visible light source offered on select models for ease of alignment
- Embedded IO-Link 1.1 communication protocol with enhanced IO-Link parameters
- Input to disable light source on transmitted beam emitter
- IP67 rated enclosure
- -40...+65 °C (-40...+149 °F) operating temperatures

Available Models









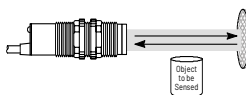

- Polarized retroreflective
- Diffuse
- Background suppression
- Background reflection
- Transmitted beam

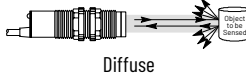
Specifications

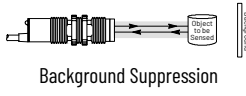
Attribute	Value
Certifications	CE Marked for all applicable directives, cULus Listed, KCC, RCM, UKCA Marked for all applicable regulations
EMC Directive	EN 60947-5-2
Standards	UL 60947-5-2
Ambient light immunity	EN 60697-5-2:2007+A:2012
For declarations of conformity and certification details, visit rok.auto/certifications .	
Functional Safety Parameters	
MTTFd	860 a
User Interface	
Status indicators	Green and orange
Adjustments	Adjustment knob depending on catalog number
Optical	
LED	Visible red on all models
Electrical	
Operating voltage	10 ...30V DC
Current consumption	Less than 35 mA
Sensor protection	Reverse polarity and short circuit

Attribute	Value
Output	
Output types	NPN or PNP by catalog number
Output mode	Light and dark operate
Response Time	
Diffuse, max	0.5 ms
Transmitted beam, max	0.5 ms
Polarized retroreflective, max	0.5 ms
Clear object detection, max	0.5 ms
Background suppression, max	0.66 ms
Background reflection, max	0.66 ms
Load Current	
Resistive load, max	100 mA
Mechanical	
Housing material	ABS
Lens material	Acrylic
Environmental	
Enclosure rating	IP67
Operating temperature	-40...+65 °C (-40...+149 °F)

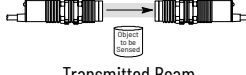
Product Selection

Sensing Mode	Light Source	Sensing Distance	Sensitivity Adjustment	Output Function	Output Type	Cat. No.
 Polarized Retroreflective	Visible red	6 m with 92-125 reflector	No adjustment knob	Complementary light and dark operate	NPN	42CE-P2MNB1-D4
			Adjustment knob		PNP	42CE-P2MPB1-D4 
 Diffuse	Visible red	800 mm	Adjustment knob	Complementary light and dark operate	NPN	42CE-D2MNA1-D4
					PNP	42CE-D2MPA1-D4 
 Background Suppression	Visible red	50 mm	No adjustment knob	Complementary light and dark operate	NPN	42CE-B2MNB1-D4
		100 mm			PNP	42CE-B2MPB1-D4 
		210 mm	Adjustment knob		NPN	42CE-B2MNB2-D4
 Background Reflection	Visible red	210 mm	Adjustment knob	Complementary light and dark operate	PNP	42CE-B2MPB2-D4 
					NPN	42CE-B2MNA3-D4
 Transmitted Beam	Visible red	25,000 mm	No adjustment knob	—	—	42CE-E2EZB1-D4 
				Complementary light and dark operate	NPN	42CE-R2MNB1-D4
					PNP	42CE-R2MPB1-D4 

IMPORTANT

Connection Options ⁽¹⁾: The following suffixes describe the available connection options:

- D4: Describes an integral 4-pin DC micro (M12) quick-disconnect for DC models.
- A2: Describes a 2 m (6.6 ft) PVC cable.

(1) Additional connection options may be available. See the ProposalWorks™ tool for available options by sensing mode.

Status Indicators and User Interface

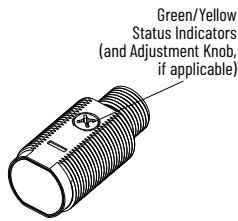

Table 1 - Standard I/O Operating Mode Indication

Color	Status	Description
Green	OFF	Power is OFF
	ON	Power is ON
	Flash (6 Hz)	Unstable light: $0.8 X < \text{margin} < 1.5X$
	Flash (1.4 Hz)	Output short circuit protection active
Orange	OFF	Output de-energized
	ON	Output energized

Table 2 - IO-Link Operating Mode Indication

Color	Status	Description
Green	OFF	Power is OFF
	Flash (1 Hz)	Power is ON
Orange	OFF	Output de-energized
	ON	Output energized



See rockwellautomation.com/en-us/products/hardware/allen-bradley/sensors-and-switches/presence-sensors/photoelectric-sensors for additional details about the operation of the RightSight C18 in IO-Link mode.

The green status indicator can also serve as a setup alignment aid that indicates that a margin of 1.5 has been reached. The sensor receives at least 1.5 times the signal strength back from the target that is required to trigger an output signal. In general, it is desirable to have a higher margin to help overcome any deteriorating environmental conditions, that is, dust build-up on the sensor lens. When aligning the sensor, the optimum performance can be obtained if this margin indicator is illuminated with the target in place. When aligning diffuse mode sensors, verify that the sensitivity is set at its maximum setting; use the single-turn adjustment knob. Pan the sensor left, right, up, and down to center the beam on the target. Decrease this setting to help prevent the sensor from detecting a background object. If this problem persists, the application requires the use of a background suppression, background reflection, or retroreflective sensing mode.

For sensor alignment, see the 42CE RightSight C18 Photoelectric Sensors Installation Instructions, publication [42CE-IN001](#).

Wiring

The quick-disconnect connector is shown in the following diagrams. The pin numbers correspond to plug connectors on the sensor.

Figure 1 - Integral Micro (M12) QD Pinout

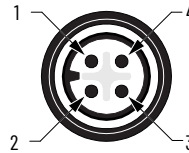

Output Wiring

Figure 2 - PNP Complementary Models

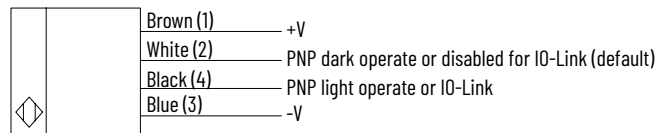
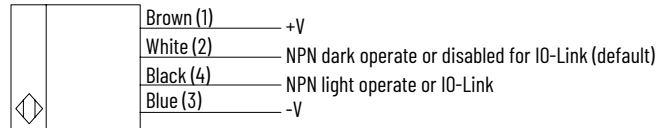
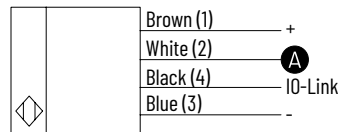

Figure 3 - NPN Complementary Models



Transmitted Beam Emitter



Item	Description
A	For normal operation, the black wire (Pin 4) needs no connection. To deactivate the light source, connect the black wire (Pin 4) to +V.

The IO-Link output Pin 4 (black) does not support the connection of multiple sensors in series (for example, one sensor powers the next sensor). The connection of multiple sensors in series can be achieved when using Pin 2 (white) outputs or by ordering a non-IO-Link catalog number.

Visit rok.auto/knowledgebase or contact your local Allen-Bradley distributor or Rockwell Automation sales office for specific ordering information.

Typical Response Curves

Diffuse

Figure 4 - 800 mm (31.5 in.) Sensing Distance - Margin Curves

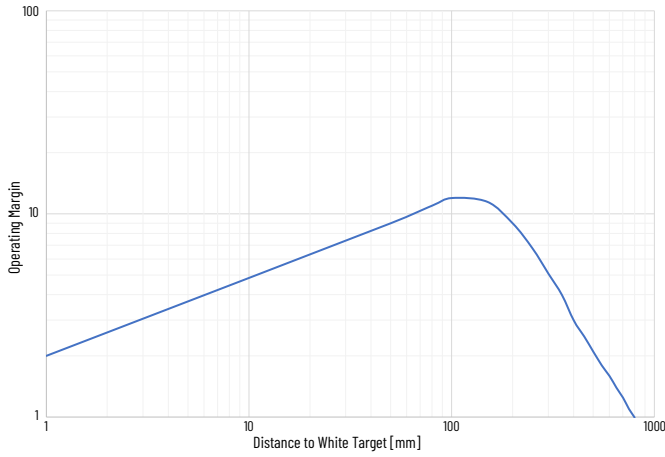

Polarized Retroreflective

Figure 6 - 6 m (19.7 ft) Sensing Range - Margin Curve

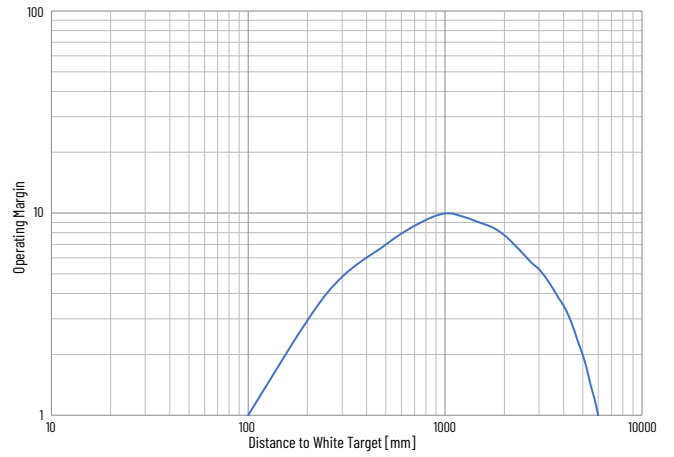

Figure 5 - 800 mm (31.5 in.) Sensing Distance - Beam Pattern

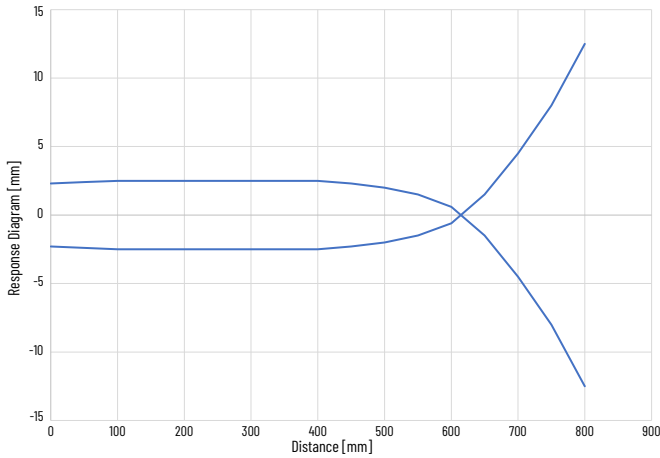
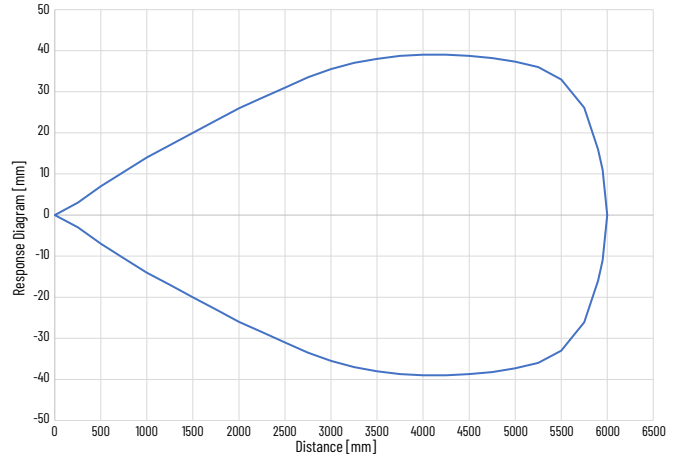

Figure 7 - 6 m (19.7 ft) Sensing Range - Beam Pattern



Background Suppression

Figure 8 - 50 mm (1.97 in.) Sensing Range - Margin Curves

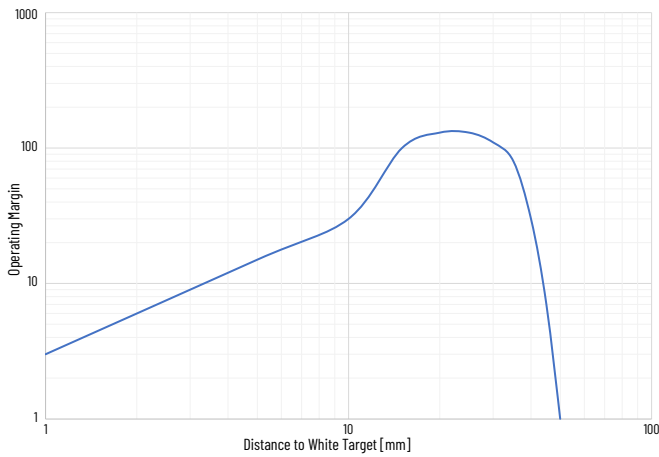

Figure 11 - 100 mm (3.94 in.) Sensing Range - Beam Pattern

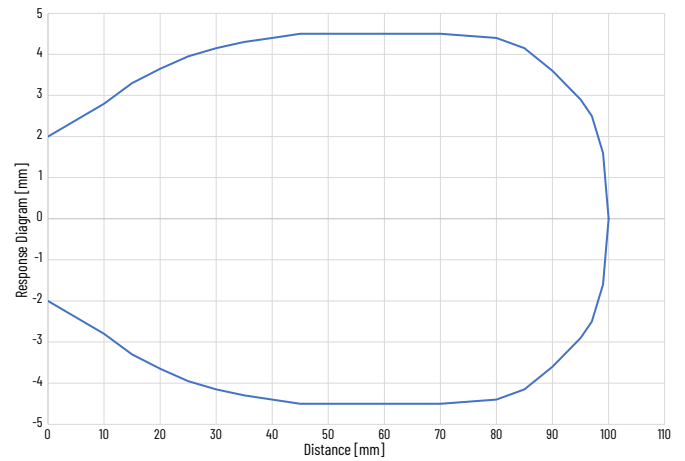

Figure 9 - 50 mm (1.97 in.) Sensing Range - Beam Pattern

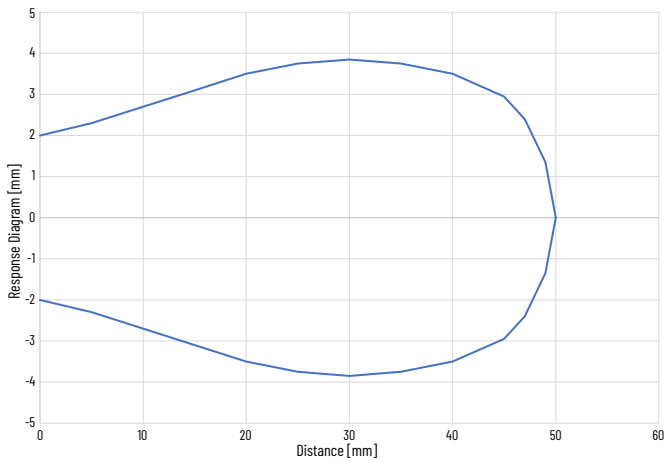

Figure 12 - 210 mm (8.27 in.) Sensing Range - Margin Curves

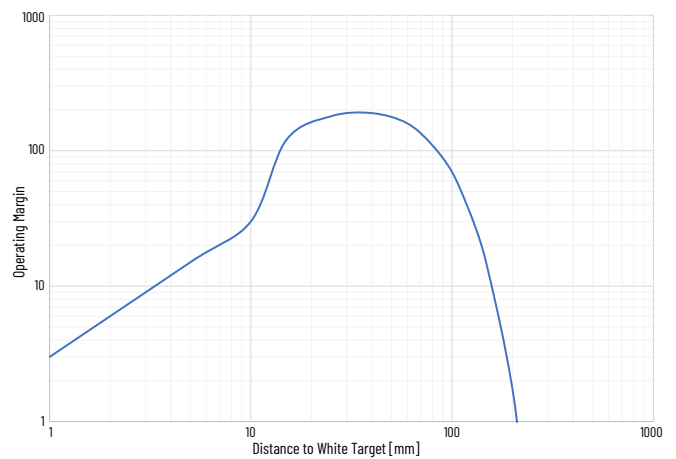

Figure 10 - 100 mm (3.94 in.) Sensing Range - Margin Curves

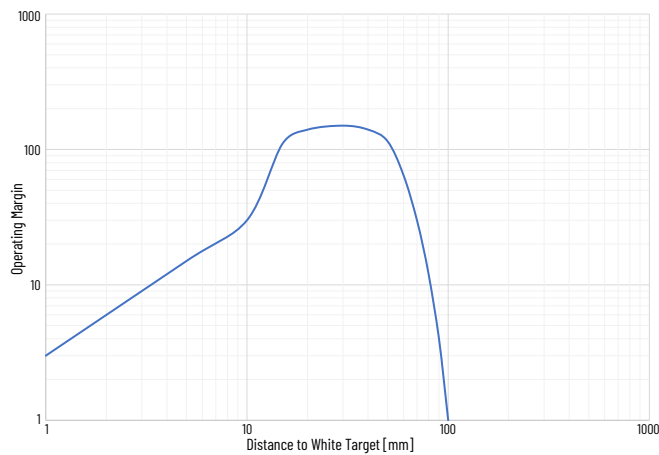
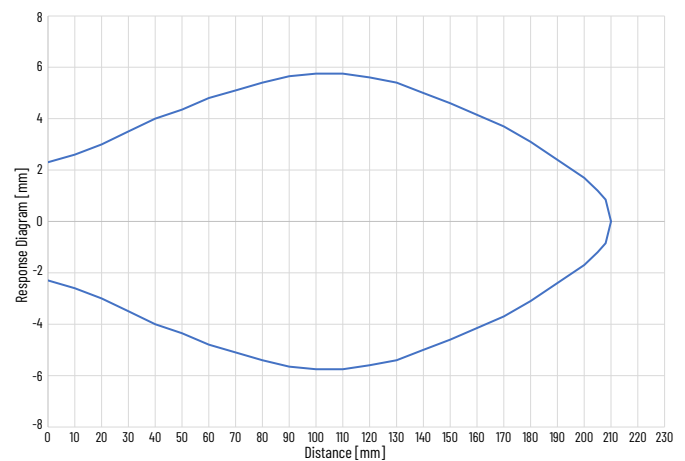

Figure 13 - 210 mm (8.27 in.) Sensing Range - Beam Pattern



Background Reflection

Figure 14 - 210 mm (8.27 in.) Sensing Range - Margin Curves

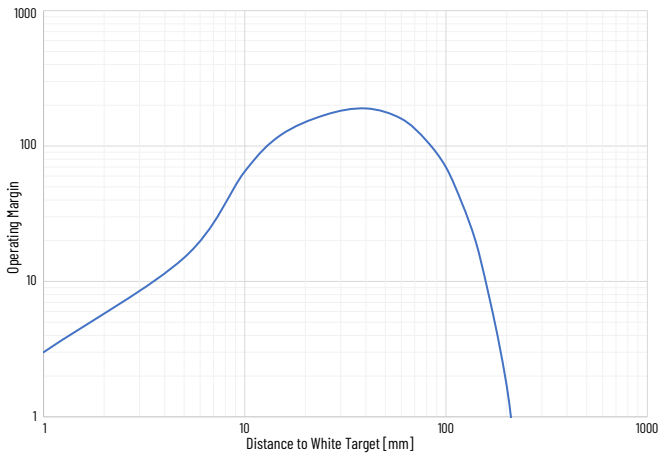
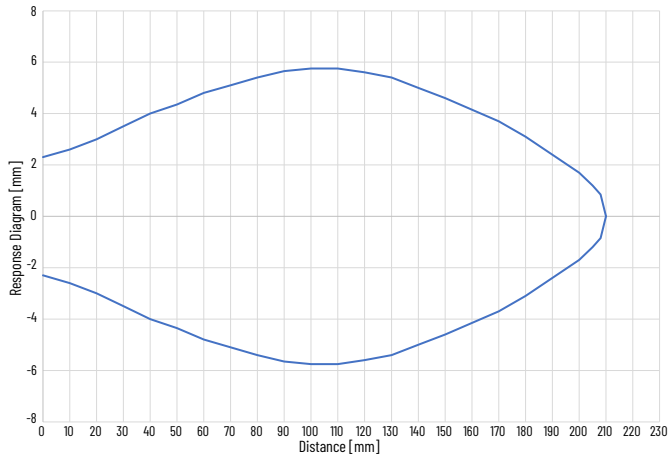

Figure 15 - 210 mm (8.27 in.) Sensing Range - Beam Patterns



Transmitted Beam

Figure 16 - 25 m (82 ft) Sensing Range - Margin Curves

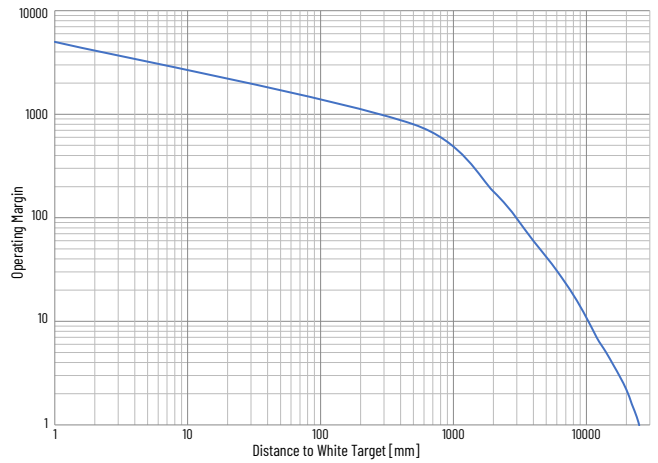
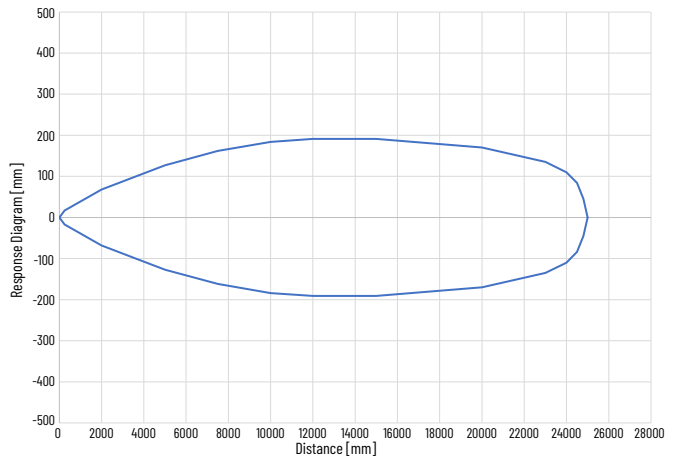

Figure 17 - 25 m (82 ft) Sensing Range - Beam Pattern



Approximate Dimensions

Dimensions shown in mm (in.).

Figure 18 - 2 m (6.6 ft) Cable Models

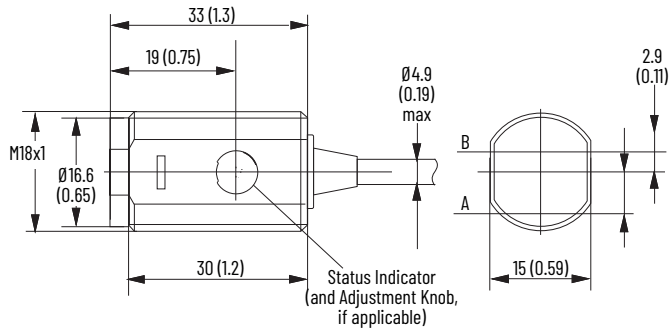

Figure 19 - Integral Micro (M12) QD Models

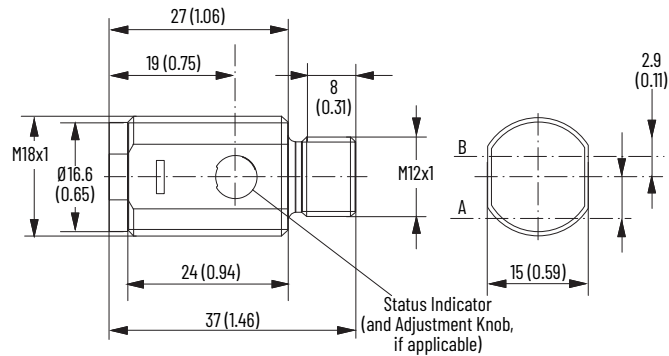

Table 3 - Emitter and Receiver Axis Position

Sensing Mode	A [mm (in.)]	B [mm (in.)]
Diffuse	3.5 (0.14)	3.5 (0.14)
Background suppression	4.5 (0.18)	2.9 (0.11)
Background reflection	3.5 (0.14)	3.5 (0.14)
Polarized retroreflective	3.5 (0.14)	3.5 (0.14)
Transmitted beam emitter	0 (0)	
Transmitted beam receiver	0 (0)	

Rockwell Automation Support

Use these resources to access support information.

Technical Support Center	Find help with how-to videos, FAQs, chat, user forums, Knowledgebase, and product notification updates.	rok.auto/support
Local Technical Support Phone Numbers	Locate the telephone number for your country.	rok.auto/phonesupport
Technical Documentation Center	Quickly access and download technical specifications, installation instructions, and user manuals.	rok.auto/techdocs
Literature Library	Find installation instructions, manuals, brochures, and technical data publications.	rok.auto/literature
Product Compatibility and Download Center (PCDC)	Download firmware, associated files (such as AOP, EDS, and DTM), and access product release notes.	rok.auto/pcdc

Documentation Feedback

Your comments help us serve your documentation needs better. If you have any suggestions on how to improve our content, complete the form at rok.auto/docfeedback.

Waste Electrical and Electronic Equipment (WEEE)







At the end of life, this equipment should be collected separately from any unsorted municipal waste.

Allen-Bradley, expanding human possibility, ProposalWorks, RightSight, and Rockwell Automation are trademarks of Rockwell Automation, Inc. Trademarks not belonging to Rockwell Automation are property of their respective companies.

Rockwell Automation maintains current product environmental compliance information on its website at rok.auto/pec.

Rockwell Automation NV Commercial Registration Number 0424.293.935

Rockwell Otomasyon Ticaret A.Ş. Kar Plaza İş Merkezi E Blok Kat:6 34752, İçerenköy, İstanbul, Tel: +90 (216) 5698400 EEE Yönetmeliğine Uygundur

Connect with us.    

rockwellautomation.com — expanding **human possibility**[®]

AMERICAS: Rockwell Automation, 1201 South Second Street, Milwaukee, WI 53204-2496 USA, Tel: (1) 414.382.2000

EUROPE/MIDDLE EAST/AFRICA: Rockwell Automation NV, Pegasus Park, De Kleetlaan 12a, 1831 Diegem, Belgium, Tel: (32) 2663 0600

ASIA PACIFIC: Rockwell Automation SEA Pte Ltd, 2 Corporation Road, #04-05, Main Lobby, Corporation Place, Singapore 618494, Tel: (65) 6510 6608

UNITED KINGDOM: Rockwell Automation Ltd., Pitfield, Kiln Farm, Milton Keynes, MK11 3DR, United Kingdom, Tel: (44)(1908) 838-800

Publication 42CE-TD001B-EN-P - September 2025

Supersedes Publication 42CE-TD001A-EN-P - January 2025

Copyright © 2025 Rockwell Automation, Inc. All rights reserved. Printed in the U.S.A.