



ArmorBlock 5000 16-channel Configurable Digital I/O Module

Catalog Numbers 5032-CFGB16M12DR, 5032-CFGB16M12P5DR, 5032-CFGB16M12M12LDR

Topic	Page
Summary of Changes	1
About the Module	1
Install the Module	4
Set the Module Network Address	5
Install the Module Overlay	6
Mount the Module	6
Connect the Network, I/O, and Power Cables to the Module	8
Specifications	11
Additional Resources	11

Summary of Changes

This publication contains the following new or updated information. This list includes substantive updates only and is not intended to reflect all changes.

Topic	Page
Updated power requirements for connecting Class 2 sensors	3
Updated SELV/PELV power supply requirements	3
Updated operating temperature	11

About the Module

The ArmorBlock 5000® 16-channel configurable digital I/O module provides 16 channels that can be configured individually as input or output. The module has fast I/O ports and standard I/O ports and can be configured for input time stamp, Sequence of Events (SOE), and Scheduled Output.

IMPORTANT You must use this module with the Studio 5000 Logix Designer® application. See the ArmorBlock 5000 16-channel Configurable Digital I/O Module User Manual, publication [5032-UM002](#), for firmware/software requirements.

See the [Module Identification](#) diagram to identify the external features of the module.



ATTENTION: Read this document and the documents listed in the Additional Resources section about installation, configuration and operation of this equipment before you install, configure, operate or maintain this product. Users are required to familiarize themselves with installation and wiring instructions in addition to requirements of all applicable codes, laws, and standards.

Activities including installation, adjustments, putting into service, use, assembly, disassembly, and maintenance are required to be carried out by suitably trained personnel in accordance with applicable code of practice. If this equipment is used in a manner not specified by the manufacturer, the protection provided by the equipment may be impaired.

注意：在安装、配置、操作和维护本产品前，请阅读本文档以及“其他资源”部分列出的有关设备安装、配置和操作的相应文档。除了所有适用规范、法律和标准的相关要求之外，用户还必须熟悉安装和接线说明。

安装、调整、投运、使用、组装、拆卸和维护等各项操作必须由经过适当训练的专业人员按照适用的操作规范实施。

如果未按照制造商指定的方式使用该设备，则可能会损害设备提供的保护。

ATENCIÓN: Antes de instalar, configurar, poner en funcionamiento o realizar el mantenimiento de este producto, lea este documento y los documentos listados en la sección Recursos adicionales acerca de la instalación, configuración y operación de este equipo. Los usuarios deben familiarizarse con las instrucciones de instalación y cableado y con los requisitos de todos los códigos, leyes y estándares vigentes.

El personal debidamente capacitado debe realizar las actividades relacionadas a la instalación, ajustes, puesta en servicio, uso, ensamblaje, desensamblaje y mantenimiento de conformidad con el código de práctica aplicable. Si este equipo se usa de una manera no especificada por el fabricante, la protección provista por el equipo puede resultar afectada.

ATENÇÃO: Leia este e os demais documentos sobre instalação, configuração e operação do equipamento que estão na seção Recursos adicionais antes de instalar, configurar, operar ou manter este produto. Os usuários devem se familiarizar com as instruções de instalação e fiação além das especificações para todos os códigos, leis e normas aplicáveis.

É necessário que as atividades, incluindo instalação, ajustes, colocação em serviço, utilização, montagem, desmontagem e manutenção sejam realizadas por pessoal qualificado e especializado, de acordo com o código de prática aplicável.

Caso este equipamento seja utilizado de maneira não estabelecida pelo fabricante, a proteção fornecida pelo equipamento pode ficar prejudicada.

ВНИМАНИЕ: Перед тем как устанавливать, настраивать, эксплуатировать или обслуживать данное оборудование, прочитайте этот документ и документы, перечисленные в разделе «Дополнительные ресурсы». В этих документах изложены сведения об установке, настройке и эксплуатации данного оборудования. Пользователи обязаны ознакомиться с инструкциями по установке и прокладке соединений, а также с требованиями всех применимых норм, законов и стандартов.

Все действия, включая установку, наладку, ввод в эксплуатацию, использование, сборку, разборку и техническое обслуживание, должны выполняться обученным персоналом в соответствии с применимыми нормами и правилами.

Если оборудование используется не предусмотренным производителем образом, защита оборудования может быть нарушена.

注意：本製品を設置、構成、稼働または保守する前に、本書および本機器の設置、設定、操作についての参考資料の該当箇所に記載されている文書に目を通してください。ユーザーは、すべての該当する条例、法律、規格の要件に加えて、設置および配線の手順に習熟している必要があります。

設置調整、運転の開始、使用、組立て、解体、保守を含む諸作業は、該当する実施規則に従って訓練を受けた適切な作業員が実行する必要があります。

本機器が製造メーカーにより指定されていない方法で使用されている場合、機器により提供されている保護が損なわれる恐れがあります。

ACHTUNG: Lesen Sie dieses Dokument und die im Abschnitt „Weitere Informationen“ aufgeführten Dokumente, die Informationen zu Installation, Konfiguration und Bedienung dieses Produkts enthalten, bevor Sie dieses Produkt installieren, konfigurieren, bedienen oder warten. Anwender müssen sich neben den Bestimmungen aller anwendbaren Vorschriften, Gesetze und Normen zusätzlich mit den Installations- und Verdrahtungsanweisungen vertraut machen.

Arbeiten im Rahmen der Installation, Anpassung, Inbetriebnahme, Verwendung, Montage, Demontage oder Instandhaltung dürfen nur durch ausreichend geschulte Mitarbeiter und in Übereinstimmung mit den anwendbaren Ausführungsvorschriften vorgenommen werden.

Wenn das Gerät in einer Weise verwendet wird, die vom Hersteller nicht vorgesehen ist, kann die Schutzfunktion beeinträchtigt sein.

ATTENTION : Lisez ce document et les documents listés dans la section Ressources complémentaires relatifs à l'installation, la configuration et le fonctionnement de cet équipement avant d'installer, configurer, utiliser ou entretenir ce produit. Les utilisateurs doivent se familiariser avec les instructions d'installation et de câblage en plus des exigences relatives aux codes, lois et normes en vigueur. Les activités relatives à l'installation, le réglage, la mise en service, l'utilisation, l'assemblage, le démontage et l'entretien doivent être réalisées par des personnes formées selon le code de pratique en vigueur.

Si cet équipement est utilisé d'une façon qui n'a pas été définie par le fabricant, la protection fournie par l'équipement peut être compromise.

주의：본 제품 설치, 설정, 작동 또는 유지 보수하기 전에 본 문서를 포함하여 설치, 설정 및 작동에 관한 참고 자료 섹션의 문서들을 반드시 읽고 숙지하십시오. 사용자는 모든 관련 규정, 법규 및 표준에서 요구하는 사항에 대해 반드시 설치 및 배선 지침을 숙지해야 합니다.

설치, 조정, 가동, 사용, 조립, 분해, 유지보수 등 모든 작업은 관련 규정에 따라 적절한 교육을 받은 사용자를 통해서만 수행해야 합니다.

본 장비를 제조사가 명시하지 않은 방법으로 사용하면 장비의 보호 기능이 손상될 수 있습니다.

ATTENZIONE Prima di installare, configurare ed utilizzare il prodotto, o effettuare interventi di manutenzione su di esso, leggere il presente documento ed i documenti elencati nella sezione "Altre risorse", riguardanti l'installazione, la configurazione ed il funzionamento dell'apparecchiatura. Gli utenti devono leggere e comprendere le istruzioni di installazione e cablaggio, oltre ai requisiti previsti dalle leggi, codici e standard applicabili.

Le attività come installazione, regolazioni, utilizzo, assemblaggio, disassemblaggio e manutenzione devono essere svolte da personale adeguatamente addestrato, nel rispetto delle procedure previste. Qualora l'apparecchio venga utilizzato con modalità diverse da quanto previsto dal produttore, la sua funzione di protezione potrebbe venire compromessa.

DIKKAT: Bu ürünün kurulumu, yapılandırılması, işletilmesi veya bakımı öncesinde bu dokümanı ve bu ekipmanın kurulumu, yapılandırılması ve işletimi ile ilgili ilave Kaynaklar bölümünde yer listelenmiş dokümanları okuyun. Kullanıcılar yürürlükteki tüm yönetmelikler, yasalar ve standartların gereksinimlerine ek olarak kurulum ve kablolama talimatlarını da öğrenmek zorundadır.

Kurulum, ayarlama, hizmete alma, kullanma, parçaları birleştirme, parçaları sökme ve bakım gibi aktiviteler sadece uygun eğitimleri almış kişiler tarafından yürürlükteki uygulama yönetmeliklerine uygun şekilde yapılabilir.

Bu ekipman üretici tarafından belirlenmiş amacın dışında kullanılırsa, ekipman tarafından sağlanan koruma bozulabilir.

注意事項：在安装、設定、操作或維護本產品前，請先閱讀此文件以及列於「其他資源」章節中有關安裝、設定與操作此設備的文件。使用者必須熟悉安裝和配線指示，並符合所有法規、法律和標準要求。

包括安裝、調整、交付使用、使用、組裝、拆卸和維護等動作都必須交由已經適當訓練的人員進行，以符合適用的實作法規。

如果將設備用於非製造商指定的用途時，可能會造成設備所提供的保護功能受損。

POZOR: Než začnete instalovat, konfigurovat či provázovat tento výrobek nebo provádět jeho údržbu, přečtěte si tento dokument a dokumenty uvedené v části Dodatečné zdroje ohledně instalace, konfigurace a provozu tohoto zařízení. Uživatelé se musejí vedle požadavků všech relevantních vyhlášek, zákonů a norem nutně seznámit také s pokyny pro instalaci a elektrické zapojení.

Činnosti zahrnující instalaci, nastavení, uvedení do provozu, užívání, montáž, demontáž, demontáž a údržbu musí vykonávat vhodné proškolený personál v souladu s příslušnými prováděcími předpisy.

Pokud se toto zařízení používá způsobem neodpovídajícím specifikaci výrobce, může být narušena ochrana, kterou toto zařízení poskytuje.

UWAGA: Przed instalacją, konfiguracją, użytkowaniem lub konserwacją tego produktu należy przeczytać niniejszy dokument oraz wszystkie dokumenty wymienione w sekcji Dodatkowe źródła omawiające instalację, konfigurację i procedury użytkowania tego urządzenia. Użytkownicy mają obowiązek zapoznać się z instrukcjami dotyczącymi instalacji oraz oprzewodowania, jak również z obowiązującymi kodeksami, prawem i normami.

Działania obejmujące instalację, regulację, przekazanie do użytkowania, użytkowanie, montaż, demontaż oraz konserwację muszą być wykonywane przez odpowiednio przeszkolony personel zgodnie z obowiązującym kodeksem postępowania.

Jeśli urządzenie jest użytkowane w sposób inny niż określony przez producenta, zabezpieczenie zapewniane przez urządzenie może zostać ograniczone.

OBES! Läs detta dokument samt dokumentet, som står listat i avsnittet Övriga resurser, om installation, konfigurering och drift av denna utrustning innan du installerar, konfigurerar eller börjar använda eller utföra underhållsarbete på produkten. Användare måste bekanta sig med instruktioner för installation och kabeldragning, förutom krav enligt gällande koder, lagar och standarder.

Åtgärder som installation, justering, service, användning, montering, demontering och underhållsarbete måste utföras av personal med lämplig utbildning enligt lämpligt bruk.

Om denna utrustning används på ett sätt som inte anges av tillverkaren kan det hända att utrustningens skyddsanordningar försätts ur funktion.

LET OP: Lees dit document en de documenten die genoemd worden in de paragraaf Aanvullende informatie over de installatie, configuratie en bediening van deze apparatuur voordat u dit product installeert, configureert, bedient of onderhoudt. Gebruikers moeten zich vertrouwd maken met de installatie en de bedringsinstructies, naast de vereisten van alle toepasselijke regels, wetten en normen.

Activiteiten zoals het installeren, afstellen, in gebruik stellen, gebruiken, monteren, demonteren en het uitvoeren van onderhoud mogen uitsluitend worden uitgevoerd door hiervoor opgeleid personeel en in overeenstemming met de geldende praktijkregels.

Indien de apparatuur wordt gebruikt op een wijze die niet is gespecificeerd door de fabrikant, dan bestaat het gevaar dat de beveiliging van de apparatuur niet goed werkt.

Rockwell Automation recognizes that some of the terms that are currently used in our industry and in this publication are not in alignment with the movement toward inclusive language in technology. We are proactively collaborating with industry peers to find alternatives to such terms and making changes to our products and content. Please excuse the use of such terms in our content while we implement these changes.

Environment and Enclosure



ATTENTION: This equipment is intended for use in a Pollution Degree 2 industrial environment, in overvoltage Category II applications (as defined in EN/IEC 60664-1), at altitudes up to 2000 m (6562 ft) without derating. This equipment is not intended for use in residential environments and may not provide adequate protection to radio communication services in such environments.

This equipment is supplied as enclosed equipment. It should not require additional system enclosure when used in locations consistent with the equipment Enclosure Type Ratings. Subsequent sections of this publication may contain more information regarding specific enclosure type ratings, beyond what this product provides that are required to comply with certain product safety certifications.

In addition to this publication, see:

- Industrial Automation Wiring and Grounding Guidelines, publication [1770-4.1](#), for additional install requirements.
 - NEMA Standard 250 and IEC 60529, as applicable, for explanations of the degrees of protection provided by different types of enclosure.
-

Preventing Electrostatic Discharge



ATTENTION: This equipment is sensitive to electrostatic discharge, which can cause internal damage and affect normal operation. Follow these guidelines when you handle this equipment:

- Touch a grounded object to discharge potential static.
 - Wear an approved grounding wriststrap.
 - Do not touch connectors or pins on component boards.
 - Do not touch circuit components inside the equipment.
 - Use a static-safe workstation, if available.
 - Store the equipment in appropriate static-safe packaging when not in use.
-

Electrical Safety Considerations



ATTENTION: Power to this equipment and all connected I/O must be supplied from a source compliant with the following:

- ArmorBlock 5000 I/O modules connect to an external power supply and offer a capability of up to 10 A @ 24V DC, which is >100VA. If any I/O devices connected to this equipment requires <100VA (Class 2) power to operate, the ArmorBlock 5000 I/O module must be powered by UL certified Class 2 sources (one for MSA and one for LA).
 - You must use isolated Safety Extra Low Voltage (SELV) or Protected Extra Low Voltage (PELV) power supplies for module power.
 - Make sure that all connectors and caps are securely tightened to seal properly the connections against leaks and maintain IP enclosure type requirements.
 - Use only a soft dry anti-static cloth to wipe down equipment. Do not use any cleaning agents.
 - Use cable assemblies suitable for the type rating of the equipment.
-



ATTENTION:

1. You must limit the module power source to 10 A, max, at 18...30V DC.

2. Confirm that the external module power supply is adequately sized for all installed modules.

For example, if the total module power current draw, including current inrush requirements, is 5 A, you can use a module power supply that is limited to 5 A.

Module Identification

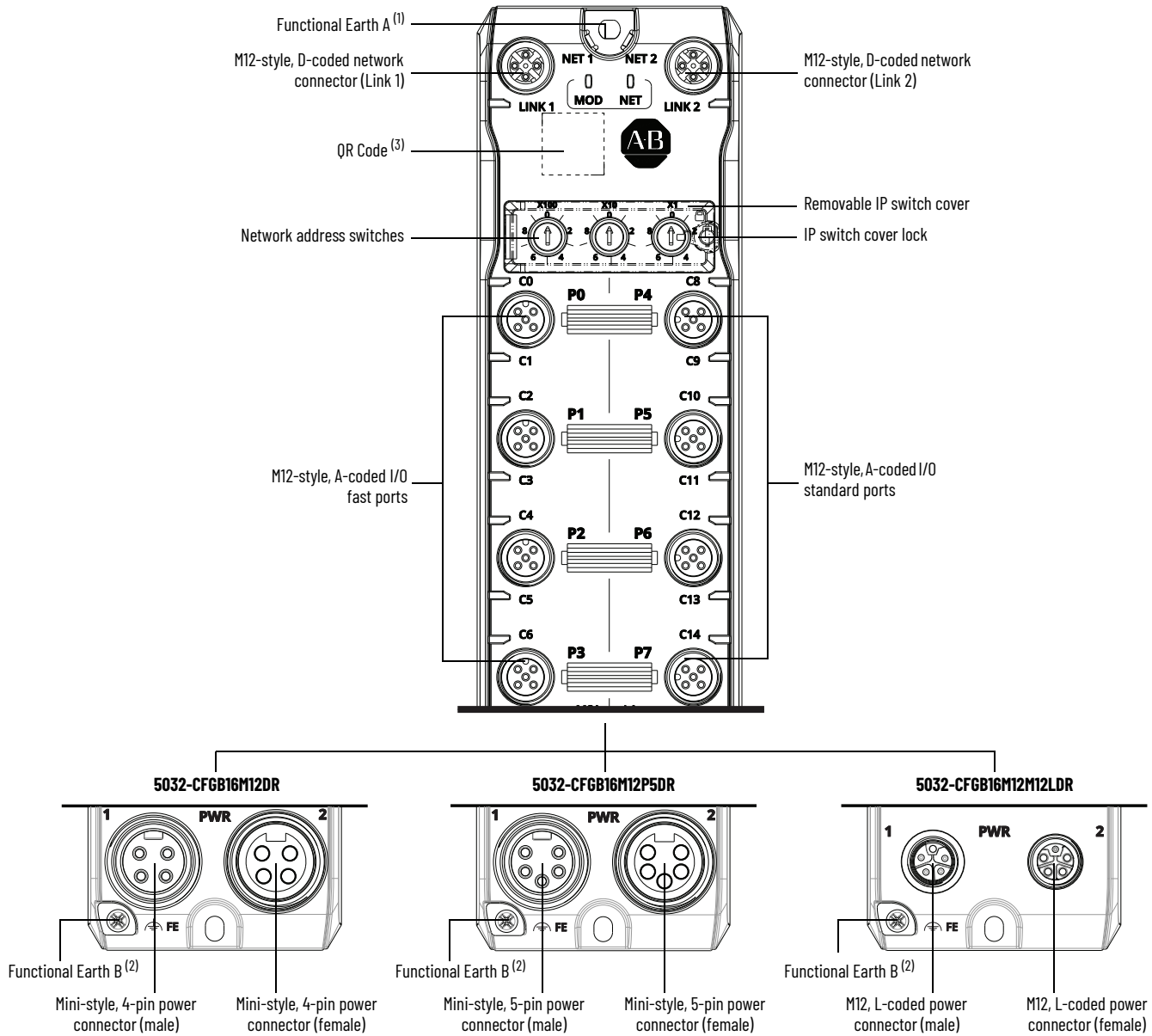

- (1) Functional Earth A grounds the module EtherNet/IP™ communication circuitry, which is designed to mitigate the effect of noise on the network. The module requires a solid earth ground connection, either through a metal screw to a grounded metal panel or through a wire. See [Network Connectors on page 8](#) for connections.
- (2) Functional Earth B grounds the module I/O and power circuitries to mitigate the effect of noise on the network. Functional Earth B is internally connected to pin 5 of power connectors in 5032-CFGB16M12P5DR and 5032-CFGB16M12M12LDR. The module requires a solid earth ground connection, either through the mini-style 5-pin or M12 L-coded power patchcord, or through a wire to the screw point. See [Power Connectors on page 9](#) for connections.
- (3) The QR Code contains a link to the product webpage that provides details on the product such as lifecycle status and documentation.

Install the Module

To install the module:

- [Set the Module Network Address](#)
- [Mount the Module](#)
- [Connect the Network, I/O, and Power Cables to the Module](#)

Set the Module Network Address

The module reads the network address switches first to determine if the switches are set to a valid number. See the [Values for Network Address Switches](#) table for available values. The module ships with the network address switches set to 999 and Dynamic Host Configuration Protocol (DHCP) enabled.

To set the network address, do one of the following:

- Adjust the network address switches.
- Use a DHCP server, such as Rockwell Automation BootP/DHCP.
- Retrieve the IP address from nonvolatile memory.

To adjust the network address switches, do the following:

1. Remove power from the module.
2. Use a small flat screwdriver or test pen to rotate the IP switch cover lock 90° counterclockwise to the unlock position.
The IP switch cover pops out slightly.

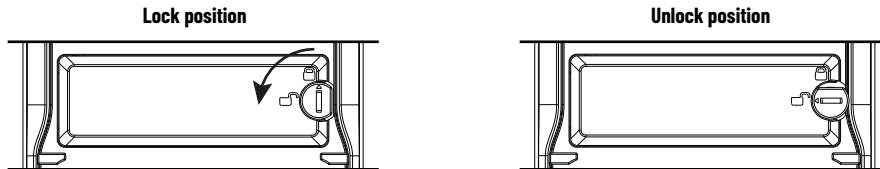

3. Remove the IP switch cover.

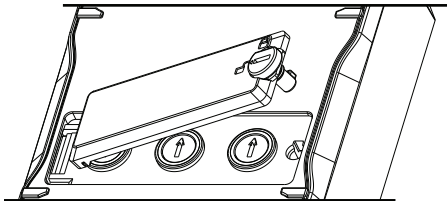

4. Set the network address to a valid value.
Use a small flat screwdriver or test pen to rotate each network address switch and align the arrow with the desired number (0...9).

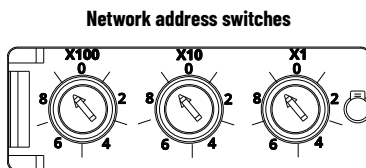

Network address switches set to default value of 999.

5. Verify that the IP switch cover lock is in the unlock position, then replace the IP switch cover over the network address switches.
Press down on the IP switch cover and use a small flat screwdriver or test pen to rotate the IP switch cover lock 90° clockwise to the lock position.
6. Reapply power to the module.

- IMPORTANT**
- Do not rotate the IP switch cover lock more than 90° clockwise or counterclockwise.
 - The IP switch cover lock should rotate smoothly between the lock and unlock positions.
 - If the IP switch cover does not fit correctly or the lock cannot be rotated smoothly, check the lock opening for any debris.
 - Verify that the IP switch cover is installed correctly to seal the network address switches against leaks and maintain IP enclosure type requirements.

Values for Network Address Switches

Value	Description
001	Sets the module IP address to 192.168.1.1. This value is valid but not recommended as this IP address is typically used by network switches.
002...253	Sets the module IP address to 192.168.1.xxx (where xxx is the value of the network address switches). Subnet mask is set to 255.255.255.0 and the gateway address is set to 0.0.0.0. The module does not have a host name that is assigned to it or uses any Domain Name Server (DNS).
254	Sets the module IP address to 192.168.1.254. This value is valid but not recommended as this IP address is typically used by network switches.
888	Resets the module to factory default settings.
999	The module checks to see if DHCP is enabled. <ul style="list-style-type: none"> • If DHCP is enabled, the module requests for an IP address from a DHCP server. The DHCP server also assigns other network address parameters. • If DHCP is not enabled, the module uses the IP address and other network address parameters that are stored in nonvolatile memory.

Install the Module Overlay

If you are using the module configured in 8-point mode, you can add the 5032-OVRLAY-QTY30 adhesive overlay on the module to align the point numbering to an 8-point module. To install the module overlay, do the following:

1. Peel off the overlay pieces from the liner.

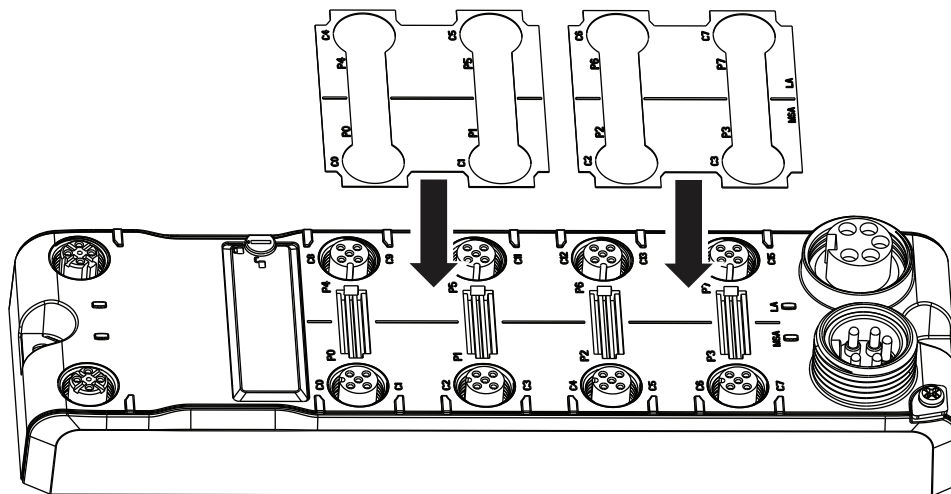

2. Align the upper overlay piece, identified by a "C0" marking on the top left, along the connector marked "C0" on the module.
3. Align the lower overlay piece, identified by a "C2" marking on the top left, along the connector marked "C4" on the module.
4. Ensure that all four circular cutout areas of each overlay piece align with the module connectors and that the status indicators are not hidden.
5. Press the overlay into place.

Mount the Module

Use the two mounting holes to mount the module directly to a panel or machine. Mounting holes accommodate M4 screws. The recommended torque specification for the screws is 0.68 N•m (6 lb•in.).

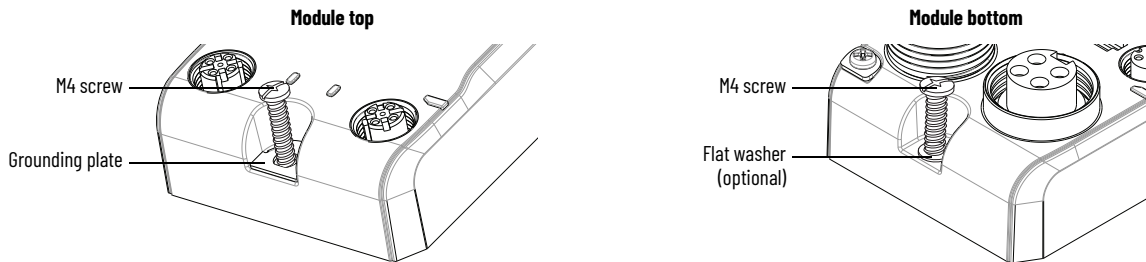

See the [Module Dimensions](#) diagram to help you mount the module.

Module Dimensions

Measurements are in millimeters (inches)

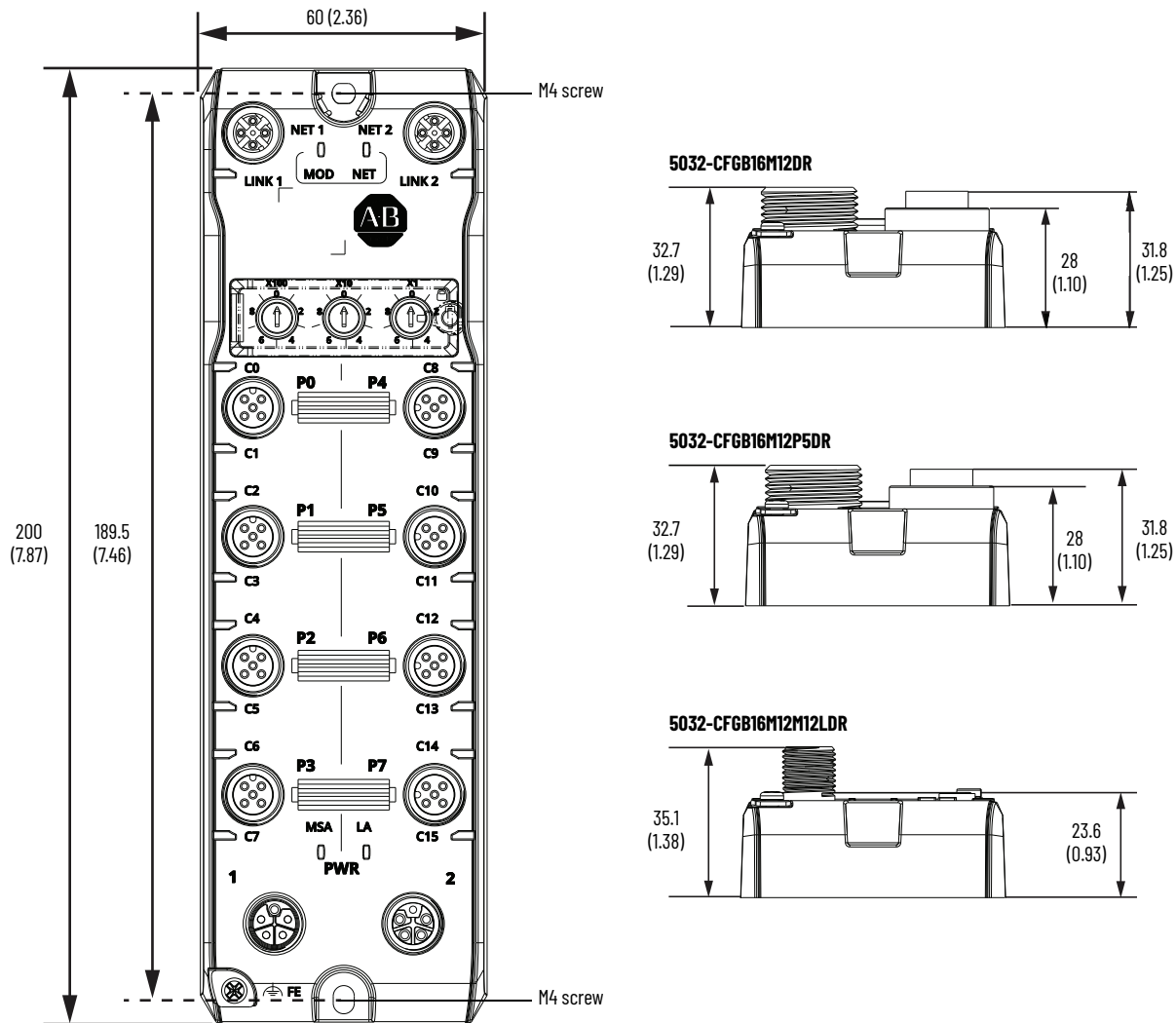

Connect the Network, I/O, and Power Cables to the Module

Sealing caps are provided to cover the unused connectors on your module. See the [Module Accessories](#) table for the list of accessories that are provided with your module.

You can use the configuration tools available at rok.auto/systemtools, or see the following publications to help select suitable Rockwell Automation cable, patchcord, and accessories:

- For network cables, see Ethernet Media Specifications Technical Data, publication [1585-TD001](#).
- For I/O and power cables, see Cordsets and Field Attachables Technical Data, publication [889-TD002](#).
- For IP switch cover and sealing caps, see ArmorBlock 5000 I/O Modules Technical Data, publication [5032-TD001](#).
- For marker cards (1492-MD6X9), see Preprinted and Custom-printed Marker Cards Selection Guide, publication [1492-SG009](#).

Connect the cables or patchcords that you have selected for your module to the appropriate ports.

Module Accessories

Item	Quantity Provided
IP switch cover	1
Network connector sealing cap	1
I/O connector sealing cap	4
Power connector sealing cap	1
Marker card – 9 markers per card, 6 x 9 mm (0.24 x 0.35 in.)	1

Network Connectors

M12-style, D-coded Connectors, Female

NET 1

View into connector

Pin	Value	Description
1	Tx+	Transmitter+
2	Rx+	Receiver+
3	Tx-	Transmitter-
4	Rx-	Receiver-
5	GND	Connector shell shield

NET 2

View into connector

Pin	Value	Description
1	Rx+	Receiver+
2	Tx+	Transmitter+
3	Rx-	Receiver-
4	Tx-	Transmitter-
5	GND	Connector shell shield



Some of the recommended network cables for daisy chains are 1585D-M4TBJM-x and 1585D-M4TBDM-x.

I/O Connectors

The ArmorBlock 5000 I/O Module has four fast I/O ports and four standard I/O ports.

Channel Number ⁽¹⁾	Fast I/O Ports								Standard I/O Ports							
	C0	C1	C2	C3	C4	C5	C6	C7	C8	C9	C10	C11	C12	C13	C14	C15
Port Number	P0	P0	P1	P1	P2	P2	P3	P3	P4	P4	P5	P5	P6	P6	P7	P7
Configure as Digital Input	Y	Y	Y	Y	Y	Y	Y	Y	Y	Y	Y	Y	Y	Y	Y	Y
Configure as Digital Output	Y	Y	Y	Y	Y	Y	Y	Y	Y	Y	Y	Y	Y	Y	Y	Y

(1) Channel numbers C0...C15 that are indicated on the module correspond to CH 0...CH 15.

M12-style, A-coded Connectors, Female

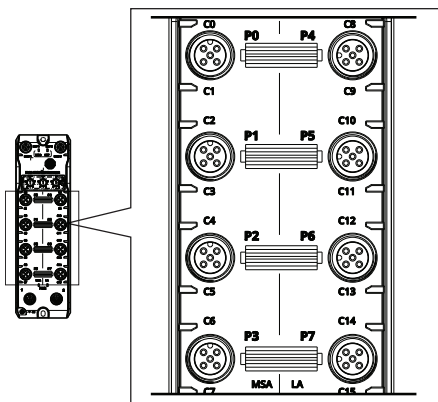

Fast ports (P0...P3)

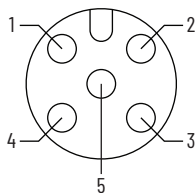

View into connector

Standard ports (P4...P7)

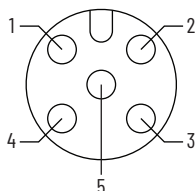

View into connector

Pin	Value	Description
1	MSA SA+	Sensor/Actuator power, sourced from MSA
2	I/O	Digital input or digital output
3	MSA-	Module/Sensor/Actuator power, GND
4	I/O	Digital input, or digital output
5	FE	Functional Earth B

Pin	Value	Description
1	LA SA+	Sensor/Actuator power, sourced from LA
2	I/O	Digital input or digital output
3	LA-	LA power, GND
4	I/O	Digital input or digital output
5	FE	Functional Earth B

Power Connectors

The module receives its required power through the male connector on the left. Use the female connector on the right to daisy chain power from this module to another ArmorBlock 5000 I/O module.

The module requires two 24V DC (nominal) supplies. These supplies are called the MSA power (Module/Sensor/Actuator) and the LA power (Local Actuator). The MSA power provides power to the microprocessor, Ethernet, and fast ports including SA power (MSA SA+) portion of the module. The LA power provides power to the standard ports with 2 A power digital outputs and SA power (LA SA+) portion of the module.

Internally, the MSA power and LA power are isolated from each other.

IMPORTANT The maximum current that any module can carry is 10 A.
 The maximum current that any pin on the mini-style power connectors can carry is 10 A.
 The maximum current that any pin on the M12 L-coded power connectors can carry is 16 A.

Mini-style, 4-pin Connectors – 5032-CFGB16M12DR

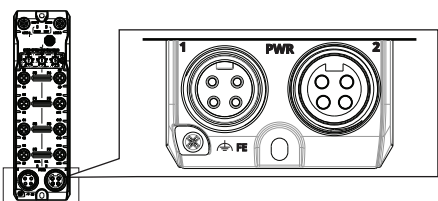

Male Input

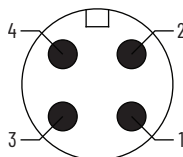

Female Output

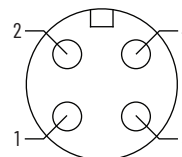

View into connectors

Pin	Value	Description
1	LA+	Power source voltage, isolated power
2	MSA+	Module/Sensor/Actuator power, V+
3	MSA-	Module/Sensor/Actuator power, GND
4	LA-	Power source voltage, isolated power, GND

Mini-style, 5-pin Connectors – 5032-CFGB16M12P5DR

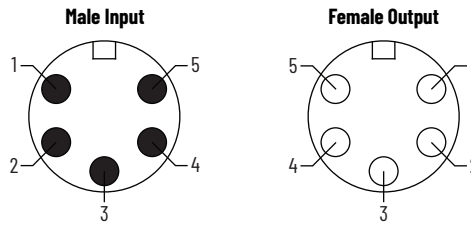
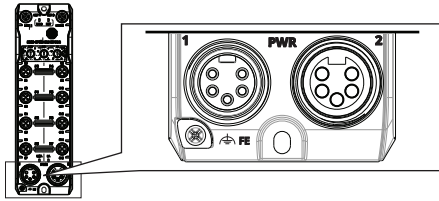

View into connectors

Pin	Value	Description
1	LA-	Power source voltage, isolated power, GND
2	MSA-	Module/Sensor/Actuator power, GND
3	FE	Functional Earth B
4	MSA+	Module/Sensor/Actuator power, V+
5	LA+	Power source voltage, isolated power

M12, L-coded Connectors – 5032-CFGB16M12M12LDR

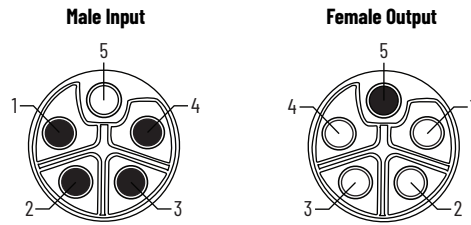
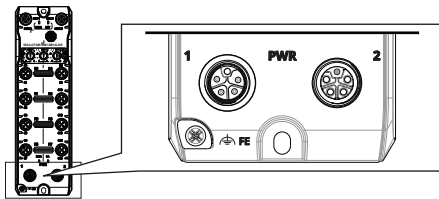

View into connectors

Pin	Value	Description
1	MSA+	Module/Sensor/Actuator power, V+
2	LA-	Power source voltage, isolated power, GND
3	MSA-	Module/Sensor/Actuator power, GND
4	LA+	Power source voltage, isolated power
5	FE	Functional Earth B

Specifications

The following table lists a subset of the module specifications. For a complete list of specifications, see the ArmorBlock 5000 I/O Modules Technical Data, publication [5032-TD001](#).

Module Specifications

Attribute	Value
Temperature, operating	IEC 60068-2-1 (Test Ad, Operating Cold), IEC 60068-2-2 (Test Bd, Operating Dry Heat), IEC 60068-2-14 (Test Nb, Operating Thermal Shock): -40 °C ≤ Ta ≤ +60 °C (-40 °F ≤ Ta ≤ +140 °F)
Temperature, ambient, max	60 °C (140 °F)
Enclosure type rating	Meets IP66, IP67, and IP69K, and Type 2 Indoor Use Only, with receptacle dust caps or cable termination
Voltage, power min	18V DC
Voltage, power max	30V DC
Current, MSA power, max per module (no Digital I/O loads, no Sensor Voltage loads, and no power daisy-chain loads)	100 mA @ 24V DC
Current, LA power, max per module (no Digital I/O loads, no Sensor Voltage Loads, and no power daisy-chain loads)	50 mA @ 24V DC
Current, MSA power plus LA power, max per module (includes Digital I/O loads, and Sensor Voltage loads)	10 A
Galvanic isolation voltage	50V (continuous), Basic Insulation Type, between MSA power and field Ethernet connectors 50V Basic Insulation Type between MSA power and LA power No isolation between individual I/O
Dimensions (HxWxD), approx (including connectors)	200 x 60 x 32.7 mm (7.87 x 2.36 x 1.29 in.) – 5032-CFGB16M12DR, 5032-CFGB16M12P5DR 200 x 60 x 35.1 mm (7.87 x 2.36 x 1.38 in.) – 5032-CFGB16M12M12LDR
Weight, approx	0.33 kg (0.73 lb) – 5032-CFGB16M12DR, 5032-CFGB16M12P5DR 0.29 kg (0.64 lb) – 5032-CFGB16M12M12LDR

Additional Resources

These documents contain additional information concerning related products from Rockwell Automation.

Resource	Description
ArmorBlock 5000 I/O Modules Technical Data, publication 5032-TD001	Provides specifications for ArmorBlock 5000 I/O modules.
ArmorBlock 5000 16-channel Configurable Digital I/O Module User Manual, publication 5032-UM002	Describes how to configure, use, and troubleshoot ArmorBlock 5000 16-channel configurable digital I/O modules.
EtherNet/IP Network Devices User Manual, publication ENET-UM006	Describes how to configure and use EtherNet/IP devices to communicate on the EtherNet/IP network.
Ethernet Reference Manual, publication ENET-RM002	Describes basic Ethernet concepts, infrastructure components, and infrastructure features.
System Security Design Guidelines Reference Manual, publication SECURE-RM001	Provides guidance on how to conduct security assessments, implement Rockwell Automation products in a secure system, harden the control system, manage user access, and dispose of equipment.
Industrial Components Preventive Maintenance, Enclosures, and Contact Ratings Specifications, publication IC-TD002	Provides a quick reference tool for Allen-Bradley® industrial automation controls and assemblies.
Safety Guidelines for the Application, Installation, and Maintenance of Solid-state Control, publication SGI-1.1	Designed to harmonize with NEMA Standards Publication No. ICS 1.1-1987 and provides general guidelines for the application, installation, and maintenance of solid-state control in the form of individual devices or packaged assemblies incorporating solid-state components.
Industrial Automation Wiring and Grounding Guidelines, publication 1770-4.1	Provides general guidelines for installing a Rockwell Automation industrial system.
Product Certifications website, rok.auto/certifications	Provides declarations of conformity, certificates, and other certification details.

You can view or download publications at rok.auto/literature.

Rockwell Automation Support

Use these resources to access support information.

Technical Support Center	Find help with how-to videos, FAQs, chat, user forums, Knowledgebase, and product notification updates.	rok.auto/support
Local Technical Support Phone Numbers	Locate the telephone number for your country.	rok.auto/phonesupport
Technical Documentation Center	Quickly access and download technical specifications, installation instructions, and user manuals.	rok.auto/techdocs
Literature Library	Find installation instructions, manuals, brochures, and technical data publications.	rok.auto/literature
Product Compatibility and Download Center (PCDC)	Download firmware, associated files (such as AOP, EDS, and DTM), and access product release notes.	rok.auto/pcdc

Documentation Feedback

Your comments help us serve your documentation needs better. If you have any suggestions on how to improve our content, complete the form at rok.auto/docfeedback.





Waste Electrical and Electronic Equipment (WEEE)



At the end of life, this equipment should be collected separately from any unsorted municipal waste.

Rockwell Automation maintains current product environmental compliance information on its website at rok.auto/pec.

Rockwell Otomasyon Ticaret A.Ş. Kar Plaza İş Merkezi E Blok Kat:6 34752 İçerenköy, İstanbul, Tel: +90 (216) 5698400 EEE Yönetmeliğine Uygundur

Connect with us.    

rockwellautomation.com — expanding **human possibility**[®]

AMERICAS: Rockwell Automation, 1201 South Second Street, Milwaukee, WI 53204-2496 USA, Tel: (1) 414.382.2000

EUROPE/MIDDLE EAST/AFRICA: Rockwell Automation NV, Pegasus Park, De Kleetlaan 12a, 1831 Diegem, Belgium, Tel: (32) 2663 0600

ASIA PACIFIC: Rockwell Automation SEA Pte Ltd, 2 Corporation Road, #04-05, Main Lobby, Corporation Place, Singapore 618494, Tel: (65) 6510 6608

UNITED KINGDOM: Rockwell Automation Ltd., Pitfield, Kiln Farm, Milton Keynes, MK11 3DR, United Kingdom, Tel: (44)(1908) 838-800

Allen-Bradley, ArmorBlock 5000, expanding human possibility, Factory Talk, Rockwell Automation, Studio 5000 Logix Designer, and TechConnect are trademarks of Rockwell Automation, Inc.

EtherNet/IP is a trademark of ODVA, Inc.

Trademarks not belonging to Rockwell Automation are property of their respective companies.

Publication 5032-IN002B-EN-P - November 2024 | Supersedes Publication 5032-IN002A-EN-P - September 2023

Copyright © 2024 Rockwell Automation, Inc. All rights reserved. Printed in Singapore.

PN-734960