



GuardLink Systems

Catalog Numbers 432ES-IG3, 440R-DG2R2T, 440R-ENETR, 440S-MF5D, 440S-MF8D, 440S-MLF8D, 440S-SF5D, 440S-SF8D, 440S-SLF8D, 898D-418U-DM2

Topic	Page
GuardLink System Overview	3
GuardLink Implementation	11
GuardLink Diagnostics	15
Safety Function Calculations	21

Notes:

A GuardLink® system is a collection of components to simplify a series connection of safety devices while achieving the highest industrial safety rating. The system has these important features:

- Simplifies the connection of series connected safety devices.
- Facilitates the scalability of the safety series connections.
- Provides diagnostic information about each device in the system without having to run a separate status wire back to the machine control system.
- Allows multiple or individual lock and unlock of guard locking interlocks in the series connected system. No need for an additional wire from the machine control system to lock and unlock the safety gate.
- Helps ease communication to the machine control system over an EtherNet/IP™ network. One solution provides both safety and non-safety communications to the machine control system. The second solution provides only non-safety communications to the machine control system.

The available GuardLink interface devices include the following:

If You Need...	Select...
<ul style="list-style-type: none"> • On-machine or in-cabinet mounting applications • Three channels to monitor up to 96 safety devices • Three zones • GuardLogix® controller support • Automatic diagnostic reporting ⁽¹⁾ • CIP Safety™ support • DLR support ⁽²⁾ 	432ES-IG3 GuardLink On-Machine EtherNet/IP Interface (see 432ES-IG3 GuardLink On-Machine Network Interface Solution)
<ul style="list-style-type: none"> • In-cabinet mounting applications only • Two channels to monitor up to 64 safety devices • One zone • ControllLogix® controller support 	440R Guardmaster® DG Safety Relay ⁽³⁾ (see 440R Guardmaster DG Safety Relay Solution on page 4)

(1) With PanelView™ 5000 displays and FactoryTalk® View SE software, see [GuardLink Diagnostics on page 15](#).

(2) For more information about DLR, see publication [ENET-AT007](#).

(3) A 440R-ENETR network interface is required for guard locking applications.

432ES-IG3 GuardLink On-Machine Network Interface Solution

The GuardLink EtherNet/IP interface is a rugged module that can be mounted outside of a control panel (including in wet environments). The interface monitors three independent channels of GuardLink-enabled devices and communicates the status of those devices to a safety rated controller over a CIP Safety EtherNet/IP network.

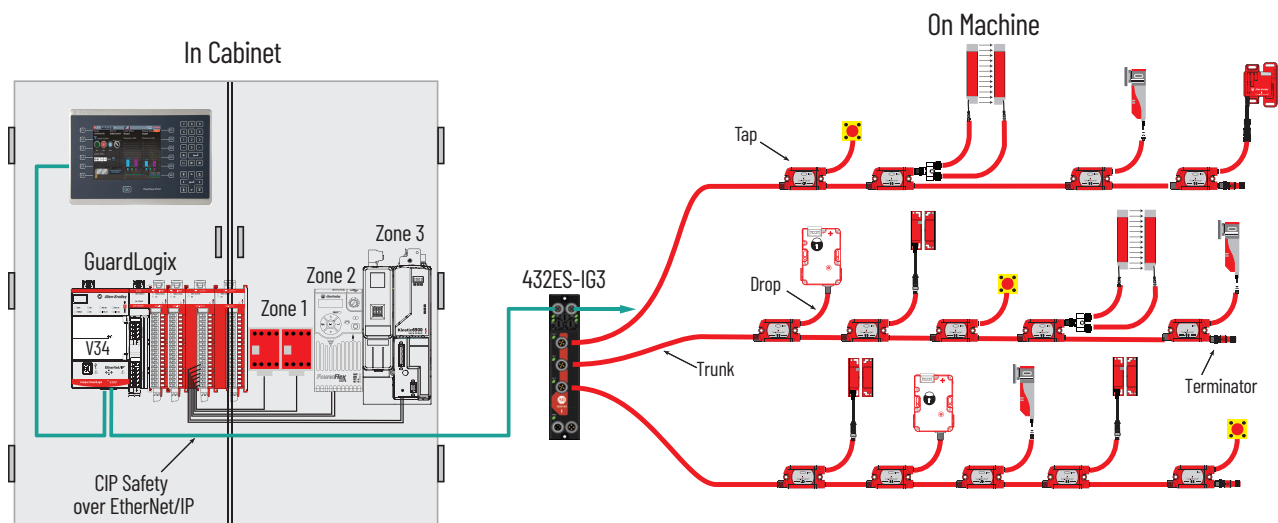

For more information, see [432ES-UM001](#).

440R Guardmaster DG Safety Relay Solution

The DG safety relay is the host of the GuardLink system. By using a sequence of push buttons on the front face, the DG safety relay can be configured for many types of safety applications.

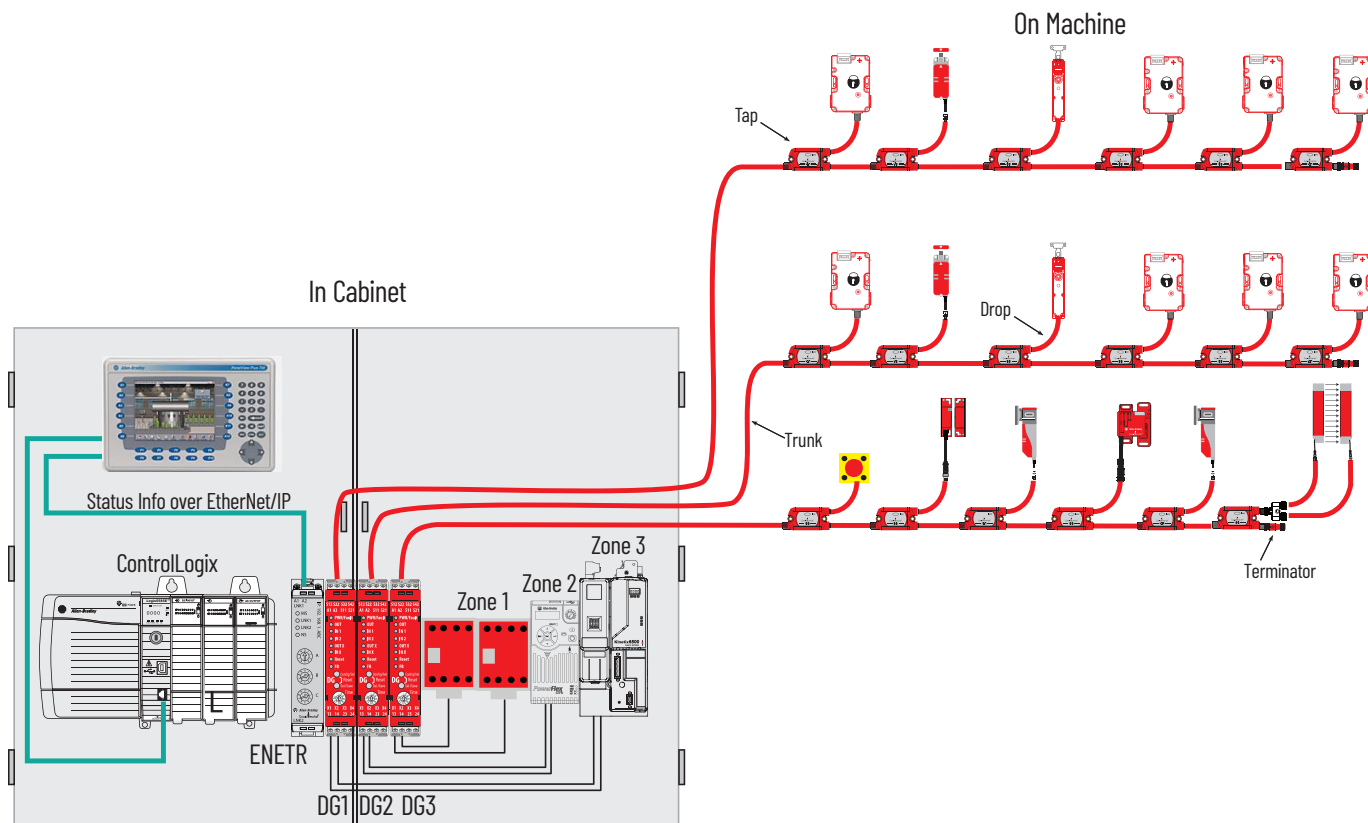

For more information, see publication [440R-UM015](#).

GuardLink Components

Each GuardLink circuit can accommodate up to 32 taps.

A typical GuardLink system consists of the following:

- One GuardLink interface
- One tap for each safety device
- One terminator for each GuardLink circuit
- Patchcords and cordsets

Taps

Taps create nodes in the GuardLink circuit. A safety device is connected to each tap. The following types of taps are available:

- GuardLink-enabled taps that interface with devices having voltage-free safety contacts
- GuardLink-enabled taps that interface with devices that have OSSD signals
- GuardLink-enabled 8-pin taps can be either Power to Release or Power to Lock
- Passive taps that interface with devices that are GuardLink-enabled
- Passive power taps that interface with devices that are GuardLink-enabled and add power to the link

GuardLink-enabled taps are available in an 8-pin and 5-pin device connection version. Passive style taps are only available in a 5-pin device connection version.

The taps are intended to be mounted on the machine, near the location of the device it monitors. The different types and versions can be connected in any order and can be mixed.

Tap Type	Description
OSSD Tap	The OSSD tap is designed to specifically interface with safety products that generate OSSD outputs. The OSSD tap does not perform testing on the OSSD signals as the input device must perform the test. The OSSD tap is looking to see if the outputs of the connected device are energized or de-energized. If the outputs are de-energized, then the tap goes to a safe state, and the input indicator is red. If the outputs of the device are energized, then the tap shows a solid or flashing green input indicator. If the OSSD tap inputs are not the same state for three or more seconds, then the tap enters a recoverable fault state. Both inputs must go to LO and then back to HI to recover.
EMSS Tap	The EMSS tap is designed to interface with two voltage-free contacts. The tap applies 24V to one side of the contact on both channels and looks for the 24V on the monitoring input. The tap pulse tests these contacts. The tap is looking to see if both contacts are closed or open. When the contacts open, the tap goes to a safe state, and the input indicator is red. When the contacts close, the tap goes to an operational state, which turns the input indicator either solid or flashing green. The EMSS tap has a 10 second simultaneity window. If one contact opens, the second contact must open within 10 seconds. Similarly, if one contact closes, the second contact must close within 10 seconds. If the simultaneity window requirement is not met, the tap goes to a recoverable fault state. To recover, both contacts must be cycled open and then closed again within 10 seconds.
Passive Tap	The passive tap is designed to interface with safety rated devices that have built-in GuardLink technology. The passive tap simply passes the GuardLink signals to and from the device. The passive tap does not operate with safety devices that have OSSD or EMSS outputs.
Passive Power Tap	The passive power tap has two significant features: <ul style="list-style-type: none"> • The passive power tap acts as a passive tap by passing the GuardLink signals directly to devices with built-in GuardLink technology • The passive power tap allows additional power to be introduced into the GuardLink circuit to compensate for voltage drops resulting from long cable lengths and numerous devices in the circuit.

Tap Cabling

The GuardLink system is designed with the intent to minimize wiring by using quick-disconnect patchcords, while also allowing some manual wiring to terminals, when pinout incompatibilities exist.

The preferred cables are the Bulletin 889D hardware (red jacket, PVC, unshielded, with epoxy coat). You can use any jacket color, however, the red is the preferred color to indicate a safety circuit. To minimize the voltage drop due to wire resistance, the preferred wiring gauge for the link cable is 18 AWG (0.823 mm²).

Visit rockwellautomation.com/en-us/products/hardware/allen-bradley/connection-devices/cables-and-cordsets/dc-micro--m12-/dc-micro-cordsets-and-patchcords.html for other options, like right-angle connectors, stainless-steel couplings, and shielded cables.

To maintain the integrity of the GuardLink signal, the wiring distance between GuardLink-enabled devices is important. There are two application cases:

- [Case 1: Includes Guard Locking Devices](#)
- [Case 2: No Guard Locking Devices on page 6](#)

For both cases, the wiring distance between the taps and the safety device is limited to 10 m (32.8 ft). Proper wiring requires at least 22 AWG (0.33 mm²) wire size for 5-conductor cables and for 8-conductor cables.

Case 1: Includes Guard Locking Devices

When the GuardLink circuit includes one or more guard locking devices, the maximum distance between GuardLink-enabled devices is 30 m (98.4 ft). If the distance between devices is greater than 30 m (98.4 ft), you must insert a GuardLink-enabled tap at a maximum of every 30 m (98.4 ft). If a device is not needed at a particular location, use a shorting plug for the device connection.

[Figure 1 on page 6](#) shows an example GuardLink circuit that includes at least one guard locking device.

Tap 1 is a GuardLink-enabled tap that can be connected to a guard locking or a non-guard locking device.

Tap 2 is a passive tap, which is connected to a GuardLink-enabled device.

[Figure 1 on page 6](#) shows tap 3 as a safety device with terminal block connections. In this case, a cordset is used to connect the safety device to the tap. The safety device can be a guard locking or non-guard locking device.

Because the GuardLink circuit has at least one guard locking switch, the maximum distance between GuardLink-enabled devices is 30 m (98.4 ft). When a passive tap is used, the cable length includes both the length of the link cable and the length of the device cable.

Figure 1 - Example Guard Locking Circuit

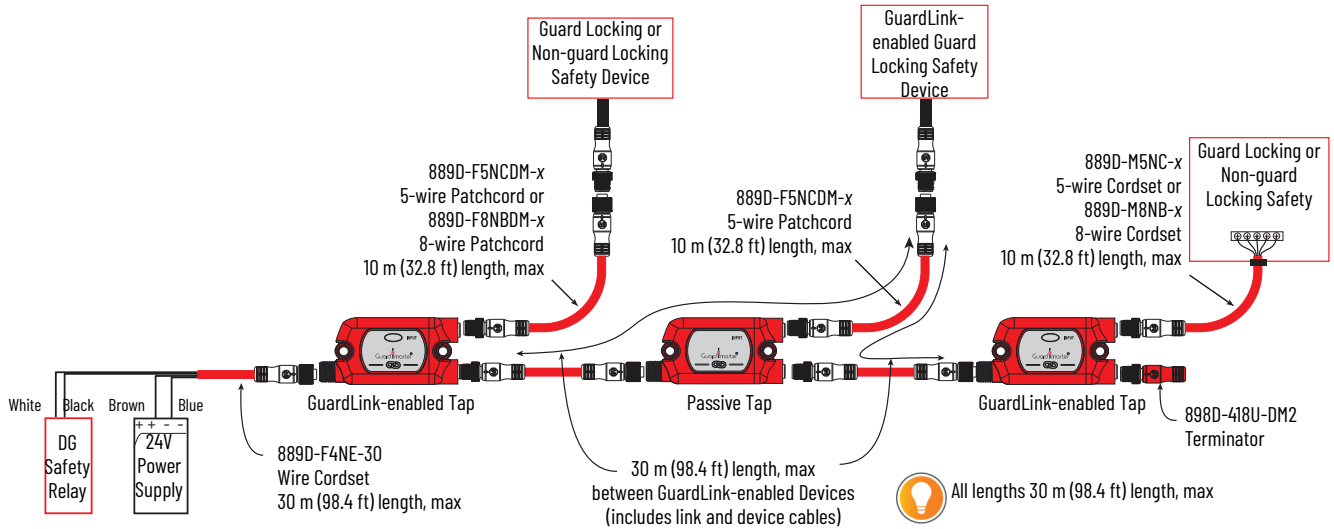

Case 2: No Guard Locking Devices

Figure 2 shows an example of a GuardLink circuit with no guard locking devices. When the GuardLink circuit excludes any guard locking devices, the maximum distance between 2...32 GuardLink-enabled devices is 100 m (328.1 ft). The distance from the DG safety relay or the 432ES-IG3 network interface to the first tap is limited to 30 m (98.4 ft). If a passive power tap is used with a shorting plug, the total length between the two neighboring GuardLink-enabled taps is 100 m (328.1 ft).

Figure 2 - Example of a Non-guard Locking Circuit

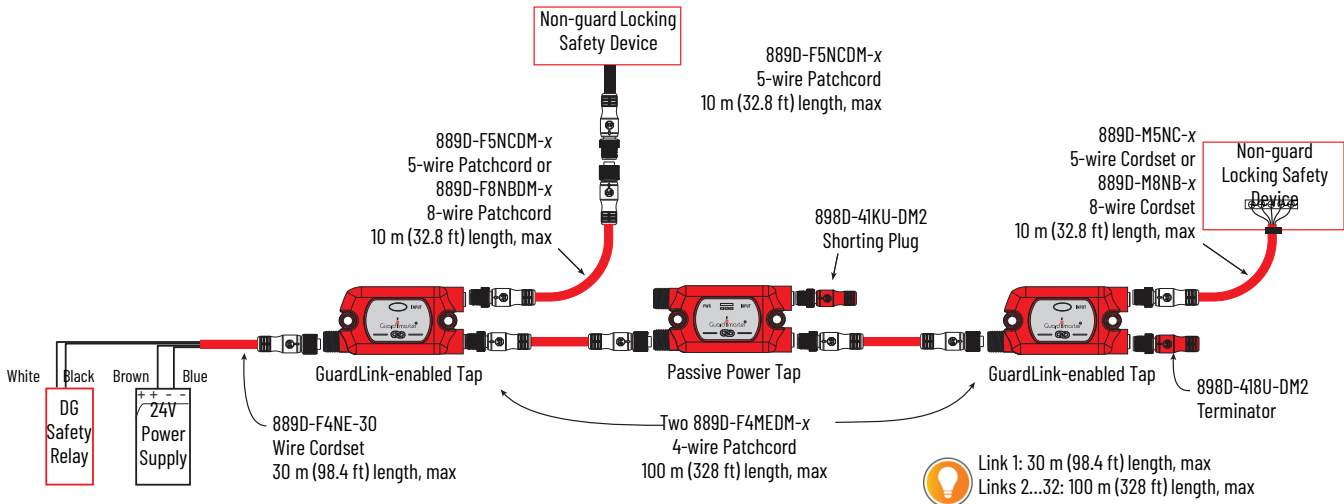

Terminator

The terminator (catalog number 898D-418U-DM2), must be installed on the J2 connector of the last tap to complete the link connection. The terminator contains internal electrical components specifically for a GuardLink system; other terminators cannot be used as substitutes.



To help troubleshoot a GuardLink system, reduce the number of taps in the GuardLink circuit by relocating the terminator. After relocation, cycle power to the DG safety relay to allow it to relearn how many taps are connected. If a 440R-ENETR interface is used, then you must cycle the power to it and update the Add-on Profile (AOP) of the interface.

For applications with the 432ES network interface, momentarily remove a link cable to cycle the power to the channel, or cycle the power to the 432ES network interface. The 432ES network interface AOP must also be updated.

Tap Replacement

A GuardLink tap can be replaced with the same type of tap while the link is powered. When the connections are remade; the GuardLink circuit recovers automatically.

When a GuardLink tap is replaced with another type of tap, which is removed or added to the circuit; cycle the power to the DG safety relay to allow it to relearn how many and what types of taps are connected. If the 440R-ENETR interface is used, then you must cycle the power to it and update the AOP of the interface.

For applications with the 432ES network interface, momentarily remove a link cable to cycle the power to the channel, or cycle the power to the 432ES network interface. The 432ES network interface AOP must also be updated.

GuardLink-enabled Products

GuardLink-enabled devices connect to the link via a passive tap 440S-PF5D or power passive tap 440S-PF5D4.

Cat. No.	Description
Safety Relay, EtherNet/IP Network Interface, and Cable to the First GuardLink-enabled Tap	
Pick One	440R-DG2R2T and 440R-ENETR Guardmaster DG (Dual GuardLink) safety relay EtherNet/IP™ network interface ⁽¹⁾
	432ES-IG3 GuardLink On-Machine™ network interface
889D-F4NE-x	Replace the x with 2, 5, 10, 15, 20, or 30 for the required cable length in meters
GuardLink-enabled Taps and Cables to Connect Between the Taps	
440S-SF5D	5-pin GuardLink-enabled tap for use with 5-pin electronic safety input devices
440S-SF8D	8-pin GuardLink-enabled tap for use with 8-pin electronic safety input devices, Power to Release (PTR)
440S-SLF8D	8-pin GuardLink-enabled tap for use with 8-pin electronic safety input devices, Power to Lock (PTL)
440S-MF5D	5-pin GuardLink-enabled tap for use with 5-pin electromechanical safety devices
440S-MF8D	8-pin GuardLink-enabled tap for use with 8-pin electromechanical safety devices, Power to Release (PTR)
440S-MLF8D	8-pin GuardLink-enabled tap for use with 8-pin electromechanical safety devices, Power to Lock (PTL)
889D-F4NEDM-x	Replace the x with OM3, OM6, 1, 2, 5, 10, 15, 20, or 30 for cable length in meters (OM3 =300 mm [11.8 in.], OM6=600 mm [23.6 in.]
Connection Cables from the GuardLink-enabled Taps to the Input Devices	
889D-F5NCDM-x	Replace the x with OM3, OM6, 1, 2, 5, or 10 for cable length in meters (OM3 =300 mm [11.8 in.], OM6=600 mm [23.6 in.]
889D-F8NBDM-x	Replace the x with OM3, OM6, 1, 2, 5, or 10 for cable length in meters (OM3 =300 mm [11.8 in.], OM6=600 mm [23.6 in.]
Accessories	
898D-418U-DM2	Terminator for the last GuardLink-enabled tap
440S-GLTAPBRK1	GuardLink-enabled tap mounting bracket (Qty 1)
440S-GLTAPBRK5	GuardLink-enabled tap mounting bracket (Qty 5)

(1) Required for guard locking applications.

Safety devices that are compatible with Smart Tap (GuardLink-enabled) taps include:

Device Type	Description	Device Type	Description
E-stop devices/ operators	<ul style="list-style-type: none"> 440E Lifeline™ 3/4/5 cable-pull safety switch 800F push buttons 	Non-contact switches	<ul style="list-style-type: none"> SensaGuard™ MC2
Guard locking switches	<ul style="list-style-type: none"> 440G-LZ/-MT TLS-3 GD2 TLS-Z 	Safety limit switches	<ul style="list-style-type: none"> 802T limit switches 440P limit switches
Hinge switches	<ul style="list-style-type: none"> 440H Ensign 3 Sprite Rotacam™ 	Trapped key interlock switches	<ul style="list-style-type: none"> 440T access 440T bolt Slamlock™ Rotary Solenoid release unit
Light curtains	<ul style="list-style-type: none"> 440L GuardShield™ 450L GuardShield 		
Tongue interlock switches	<ul style="list-style-type: none"> 440K Elf™ MT-GD2 Trojan™ 5/T15/6 Cadet™ 3 		

GuardLink Operation

The GuardLink circuit is a continuous chain of safety devices that are connected in series with only four wires. Two wires provide power and ground to the taps and devices.

The third wire (GuardLink safety signal) performs the diagnostics on the taps and the devices that are connected to each tap while in the safe state. It also carries the dynamic safety signal while in an operational state.

The fourth wire (CLU) provides the lock/unlock commands to guard locking devices on the circuit.

GuardLink State

The GuardLink chain can be in one of four states:

- Initialization
- Safe
- Operational
- Fault

Initialization State

The initialization state starts when power is applied to the GuardLink circuit and ends when the GuardLink circuit enters the safe state. If no errors exist, the GuardLink circuit transitions to the safe state; the initialization state cannot transition to the operational state.

During initialization, the DG safety relays or 432ES network interface establishes and verifies the validity of the circuit by checking the following items:

- All devices set their node number
- No more than 32 devices per channel exist
- The firmware of the taps is compatible with the DG safety relay or 432ES network interface firmware.
- The 432ES network interface detects node type and position automatically.
- Validates a terminator is attached to the GuardLink circuit.

Safe State

The GuardLink safety signal commands the DG safety relay or 432ES network interface to a safe state, which turns all safety outputs OFF. The GuardLink safety signal monitors the circuit for changes of state from the taps.

The CLU signal is HI (if guard locking devices are not used) or sending a dynamic unlock signal (if guard locking devices are used). The taps indicate this state by a steady red Link indicator.

Operational State

The GuardLink operational state is described as the GuardLink safety signal that generates a specific dynamic signal to the DG safety relay or 432ES network interface and the CLU signal being LO. The state of the DG safety relay or 432ES network interface safety outputs can be OFF or ON.

The state depends on the configuration, other safety device inputs, the feedback monitoring input, and the reset input.

Fault State

The DG safety relay or 432ES network interface and the taps have two fault states: recoverable and nonrecoverable. When a fault occurs, the taps and DG safety relay or 432ES network interface are in a safe state. Diagnostic information is provided by the indicators.

Recoverable faults can be cleared by cycling the faulted input devices. Nonrecoverable faults require the power to the cycled and can also require troubleshooting and correction of the fault. When an EtherNet/IP interface is used, the machine control system can issue a fault reset (equivalent to a power cycle).

GuardLink Transition from Safe State to Operational State

When the GuardLink signal is in the safe state, the DG safety relay or 432ES network interface holds the CLU signal in the high or dynamic unlocking state. The DG safety relay or 432ES network interface puts all taps in the safe state. For the GuardLink signal to return to the operational state, the DG safety relay or 432ES network interface must know that all taps are ready to go to the operational state. If the taps are ready to go, the CLU signal is set to LO.

Now that the CLU is set to LO, the last tap generates the safety signal. Each successive upstream device verifies that the previous device is in a safe state, confirms that its own device is in a safe state, and sends an inverted safe state signal to the next device.

When the DG safety relay or 432ES network interface receives the safety signal, the GuardLink circuit is in an operational state, and the DG safety relay or 432ES network interface continues with the evaluation of the other inputs, output monitoring, and reset inputs.

GuardLink Transition from Operational State to Safe State

Once an input device has a demand on its safety function, the tap stops sending the safety signal. When the DG safety relay or 432ES network interface no longer detects the safety signal, the CLU signal is set to HI to make all taps enter the safe state.

GuardLink Fault Reset Command

Devices with OSSD outputs can sometimes go to a fault state that requires power cycling. The Ethernet interface can be used to send a fault reset signal from the machine control system to individual devices. This reset signal effectively cycles the power to the device connected to the specified tap.

Notes:

Implementation Overview

The design of a GuardLink® circuit requires knowledge of the power requirements of the input devices and the length of the link cables. A voltage drop occurs across each tap. The cumulative voltage drop determines the number of taps that can be included in the circuit.

The GuardLink system makes it easy to monitor multiple devices over long distances when multiple access points to the hazardous area are required.

The DG safety relay or 432ES network interface monitors the GuardLink system. The GuardLink system can provide diagnostic information on each access point back to the machine control system.

The GuardLink system must be designed considering these factors:

- Voltage available at each node
- Current flowing through each node
- Cable lengths
- Wire size
- Power requirements for each tap
- Safety device power requirements

The GuardLink system is designed to operate on a 24V DC system. The maximum continuous current on the link circuit must not exceed 4 A; the taps and link cables are rated for 4 A continuous.

The Integrated Architecture® Builder (IAB) is a software tool that uses a graphical interface to facilitate the design of GuardLink and other Rockwell Automation® systems. The IAB features allow you to:

- Select available safety devices and the appropriate tap automatically selects.
- Adjust all cable lengths and voltage drops automatically calculate.
- Click and drag devices to desired positions.
- Specify supply voltage.
- Easily add additional power supplies.
- Generate a bill of materials.
- Generate a summary report of the design.

This section helps you understand the factors and calculations that IAB considers, but IAB automatically does these calculations for you.

[Figure 3 on page 12](#) identifies three tap connections: T1, T2, and T3. The voltage and safety signals are sourced to connection J1. J2 is connected to downstream taps. J3 of each tap is connected to a safety device.

Figure 3 - Tap Connections

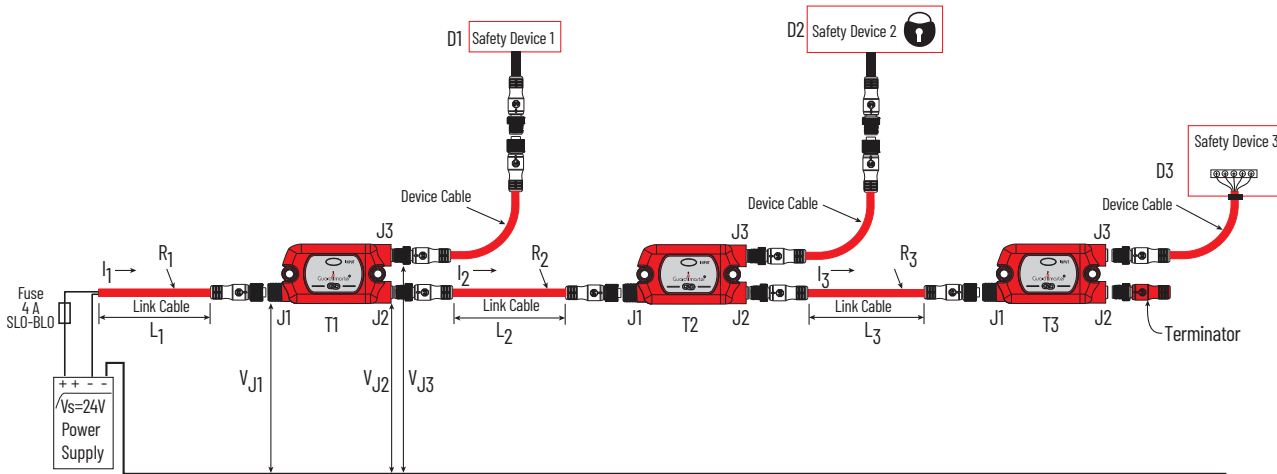

Table 1 - Key for Figure 3

Item	Description
D1, D2, D3	Safety devices
I_1, I_2, I_3	Current in the link cable (A)
I_{T1}, I_{T2}, I_{T3}	Current required by a tap (A)
I_{D1}, I_{D2}, I_{D3}	Current required by a safety device (A)
L_1, L_2, L_3	Length of link cable (m)
R_1, R_2, R_3	Resistance of wire (Ω)
T1, T2, T3	Taps
V_{J1}, V_{J2}, V_{J3}	Voltage at tap connector (V)

System Current Calculation

The GuardLink circuit current must be calculated to determine whether a significant voltage drop occurs to a safety device.

The total system current, I_1 , is the sum of the current required by the first tap plus the current required by the device that is connected to the first tap plus the current required by the downstream circuit. The total system current must not exceed 4 A, continuous.

$$I_1 = I_{T1} + I_{D1} + I_2$$

The current in each segment of the GuardLink circuit is calculated in a similar fashion.

$$I_2 = I_{T2} + I_{D2} + I_3$$

$$I_3 = I_{T3} + I_{D3}$$

The total system current, I_1 , is therefore the sum of the device currents plus the sum of the tap currents.

$$I_1 = \sum I_T + \sum I_D$$

Voltage Drop Consideration

With the potential of using up to 32 taps and long cable lengths between taps, the voltage available to the safety devices at connector J3 must be calculated.

The voltage available to the safety device has two components:

- The voltage drop due to the wire resistance of the cables
- The voltage drop within the tap

The resistance of the recommended 18 AWG (0.823 mm²) cordsets and patchcords is (0.02095 ohms/m (0.00664 ohms/ft)). The wire resistance of the cordset from the power supply to tap 1 (R₁) is:

$$R_1 = 0.02095 * L_1$$

The wire resistance must be considered for both the power and ground; therefore the voltage drop is multiplied by two. The voltage at connector J1 of tap T1 (V_{J1}) is:

$$V_{J1} = 2 * I_1 * R_1$$

The tap has a small voltage from connector J1 to J2. The typical voltage at connector J2 (V_{J2}) drop through the tap from J1 to J2 is:

$$V_{J2} = V_{J1} - (2 * 0.028V)$$

The voltage available at connector J3 is dependent on the device that is connected to J3. The typical voltage drop from J1 to J3 is 0.4V when the device uses 50 mA.

$$V_{J3} = V_{J1} - 0.4V \text{ (typical)}$$

IMPORTANT The voltage drop from J1 to J3 can be as high as 1.2V with a maximum load of 500 mA at the highest rated ambient temperature.
The TLS-ZR guard locking switch voltage drop is 0.29V when locked and 0.31V when unlocked.

The taps consume 25 mA when OFF. The EMSS taps consume an additional 15 mA (7.5 mA per channel) when the contacts are closed. The OSSD taps consume an additional 6 mA (3 mA per channel), when the outputs are ON.

A spreadsheet can be used to calculate the voltage available to the safety device. [Table 2](#) shows the voltage available to the safety device of a number of different devices. If the power supply voltage is set to 24V, and the cable is the recommended 18 AWG (0.823 mm²), the voltage available to the safety devices is shown in the right-hand column.

When guard locking devices are used in the circuit, the taps and wiring components are subjected to momentary surges in current. With the sequential operation of the lock/unlock command, the momentary surges do not adversely affect the performance of the GuardLink circuit.

The operating voltage specification of the tap is 20.4...26.4V. In the example that is shown in [Table 2](#), the voltage at J1 of tap 6 has fallen below the lowest supply voltage specification of 20.4V DC. This system is not feasible, and remedial action must be taken (see [Table 3 on page 14](#)).

IMPORTANT [Table 2](#) assumes the following:

- Supply voltage = 24V
- Link cable wire gauge = 18 AWG (0.823 mm²)
- Link wire resistance = 0.02095 ohms/m

Table 2 - Voltage Calculation at 24V Supply

Tap	Cable Length [m (ft)]	Safety Device	Tap + Device Current (mA)	Total Current (mA)	J1 Voltage (V)	J3 Voltage Typical (V)
1	15 (49.2)	SensaGuard™ (Ser A)	81	1105	23.24	22.84
2	15 (49.2)	SensaGuard (Ser A)	81	1024	22.54	22.14
3	15 (49.2)	Lite Lock 440G-LZ	135	943	21.90	21.50
4	15 (49.2)	800F E-stop	40	808	21.34	20.94
5	15 (49.2)	Lifeline™ 4	40	768	20.82	20.42
6	15 (49.2)	LifeLine 5	81	728	20.32	19.92
7	15 (49.2)	TLSZR-GD2 PLe	135	647	19.88	19.48
8	15 (49.2)	TLSZR-GD2 PLe	135	512	19.53	19.13
9	15 (49.2)	Lite Lock 440G-LZ	135	377	19.27	18.87
10	15 (49.2)	SensaGuard (Ser A)	81	242	19.10	18.70
11	15 (49.2)	SensaGuard (Ser A)	81	161	18.99	18.59
12	15 (49.2)	Mechanical switch	40	80	18.94	18.54
13	15 (49.2)	Mechanical switch	40	40	18.91	18.51
14	0 (0)	—	0	0	—	—
15	0 (0)	—	0	0	—	—

The example in [Table 2](#), can be corrected in one of two ways:

- The supply voltage can be increased from 24V to 26V as shown in [Table 3](#). Now, all 13 taps meet the minimum voltage specification of 20.4V at connector J1.
- Where the voltage drops below 20.4V DC on the link, a passive power tap (catalog number 440S-PF5D4) can be added to bring the voltage on the link back to within the necessary specification.

IMPORTANT [Table 3](#) assumes the following:

- Supply voltage = 26V
- Link cable wire gauge = 18 AWG (0.823 mm²)
- Link wire resistance = 0.02095 ohms/m

Table 3 - Voltage Calculation at 26V Supply

Tap	Cable Length [m (ft)]	Safety Device	Tap + Device Current (mA)	Total Current (mA)	J1 Voltage (V)	J3 Voltage Typical (V)
1	15 (49.2)	SensaGuard Ser A	81	1105	25.24	25.84
2	15 (49.2)	SensaGuard Ser A	81	1024	24.54	24.14
3	15 (49.2)	Lite Lock 440G-LZ	135	943	23.90	23.50
4	15 (49.2)	800F E-stop	40	808	23.34	23.94
5	15 (49.2)	LifeLine 4	40	768	22.82	22.42
6	15 (49.2)	LifeLine 5	81	728	22.32	21.92
7	15 (49.2)	TLSZR-GD2 PLe	135	647	21.88	21.48
8	15 (49.2)	TLSZR-GD2 PLe	135	512	21.53	21.13
9	15 (49.2)	Lite Lock 440G-LZ	135	377	21.27	20.87
10	15 (49.2)	SensaGuard Ser A	81	242	21.10	20.70
11	15 (49.2)	SensaGuard Ser A	81	161	20.99	20.59
12	15 (49.2)	Mechanical Switch	40	80	20.90	20.54
13	15 (49.2)	Mechanical Switch	40	40	20.91	20.51
14	0 (0)	–	0	0	–	–
15	0 (0)	–	0	0	–	–

Response Time

The GuardLink circuit has a fast response time. When a safety device opens, the tap responds within 5 ms. The GuardLink safety signal then travels upstream, which takes an additional 35 µs through each upstream tap.

IAB automatically calculates your response time for the 432ES network interface. For DG safety relay response times, see publication [440R-UM015](#).

Installation

IMPORTANT See the following publications for the installation of taps, DG safety relay, and 432ES-IG3 network interface:

- [440R-UM015](#) (DG safety relay and taps)
- [432ES-UM001](#) (432ES-IG3 network interface)

For more information, see [Additional Resources on page 23](#).



GuardLink Automatic Diagnostics Compatibility

IMPORTANT Automatic diagnostics is only available with the 432ES network interface.

Products have numerous embedded diagnostics, and the coding cost to trap all potential diagnostics can be expensive. You can write code to trap the more likely occurrence, if desired. If the more unlikely fault occurs, the event is trapped and available to view from the PanelView™ 5000 or FactoryTalk® View SE Automatic Diagnostics displays.

The 432ES-IG3 network interface module works with PanelView 5000 and FactoryTalk View SE to provide automatic diagnostic reporting. With PanelView 5000 and FactoryTalk View SE, certain diagnostics automatically report without the need to write logic code. [Table 4](#) shows programming-free diagnostics that are available on GuardLink® devices.

Table 4 - Programming-free Diagnostics

Diagnostic	 432ES-IG3 Network Interface	 440S Taps	 440G-MZ Guard Locking Switch
Internal fault	✓	✓	✓
Low system power warning	✓	✓	✓
High system power warning	✓	✓	✓
Channel faulted	✓	–	–
Terminator fault	✓	–	–
Too many devices	✓	–	–
Unverified device	✓	–	–
Ethernet port disconnected	✓	–	–
Discrepancy fault	–	✓	–
Short circuit	–	✓	–
GuardLink signal fault	–	✓	✓
Invalid actuator fault	–	–	✓
Teach process error	–	–	✓
Teach limit exceeded	–	–	✓
Lock detection fault	–	–	✓
Locking fault	–	–	✓
Actuator detection fault	–	–	✓
Actuator not paired	–	–	✓
End of Life warning	–	–	✓
Overtemperature	–	–	✓
Undertemperature	–	–	✓

Automatic Diagnostics Overview

Automatic diagnostics is a system-level feature in devices that provides device diagnostics to HMIs and other clients, with zero programming. GuardLink 2.0 products come with the automatic diagnostics feature enabled by default, so the diagnostics - including device description conditions and state events - are sent to an HMI device.

You can deactivate and activate the whole feature while online or offline from the Controller Properties dialog box. You can also deactivate automatic diagnostics for a specific device in the module properties (see [Configure Automatic Diagnostics on page 16](#)).

Configure Automatic Diagnostics

On the Controller properties Advanced tab, Enable Automatic Diagnostics (Figure 4) is a new feature that was added with the 1756-L8x controllers and firmware revision 33. When enabled, it sends analog I/O modules diagnostic information to the Automatic Diagnostics Event Summary object.

Figure 4 - Controller Setting

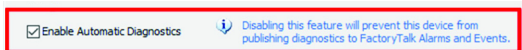

If deactivated, you only see Mode changes and loss on communication with controllers in the Automatic Diagnostics Event Summary object.

The automatic diagnostics feature is enabled by default in the Logix Designer application as shown in Figure 5. The deactivation of automatic diagnostics at the device level deactivates all device-driven diagnostics. You still get device faulted/communication loss diagnostics as the controller drives these diagnostics.

Figure 5 - 432ES Module Properties

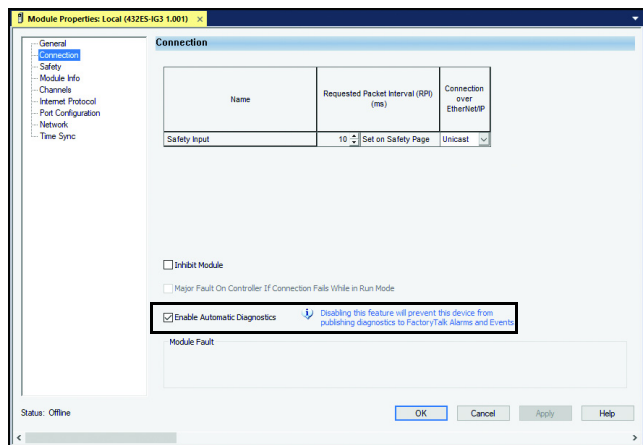

Only device Add-on Profiles (AOP) that have been updated with additional diagnostics show the Enable Automatic Diagnostics checkbox (Figure 5). You can use this checkbox to verify if the AOP of your device has been updated with additional diagnostics.

IMPORTANT Application alarms, such as analog input module high/low limit process alarms, are not included.

Automatic Diagnostics on PanelView 5000 Display

Automatic diagnostics are enabled by default on all devices. When you use a PanelView 5000 display with firmware revision 8 or later, the automatic diagnostic messages from the device display automatically. For more information, see the Automatic Diagnostics chapter in publication [9324-GR001](#).

When specific events occur, messages automatically report because the controller links to the PanelView 5000 display. In your View Designer project properties, set the Controller References to the controller of the 432ES network interface module (see [Figure 6 on page 17](#)):

- Logix project File
- HMI to controller
- Emulator to controller path

Figure 6 - Bind Controller to PanelView Project

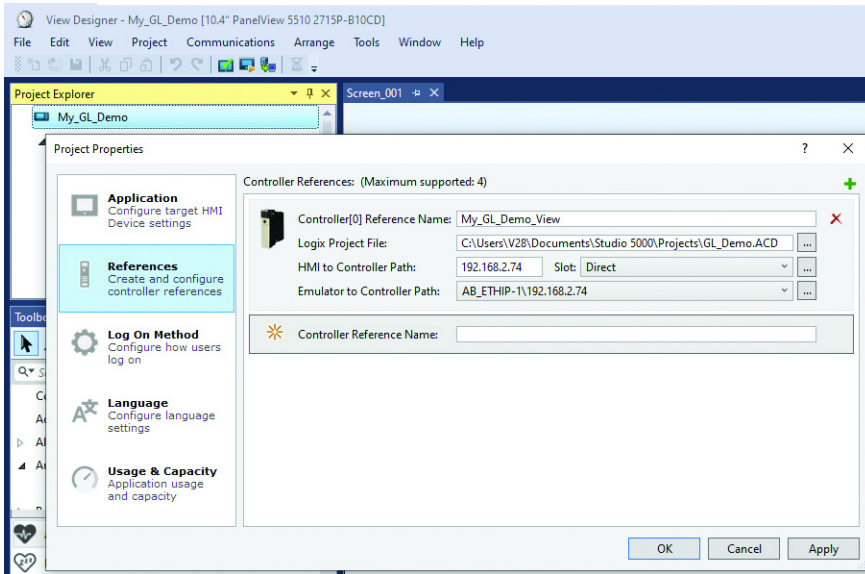

When an event occurs, the diagnostic icon shows the number of active and unsuppressed diagnostic events, as shown in [Figure 7](#). Each line entry shows:

- State: Active, inactive, or suppressed
- Event Time: Date and time when the event occurred
- Device Name: Path to the device and the device name
- Message: Preprogrammed message for the diagnostic code
- Diagnostic Code: The diagnostic code that applies to the event

IMPORTANT You can rearrange and configure additional columns. See Studio 5000 View Designer® help for more information.

Figure 7 - Diagnostics Page on PanelView 5510

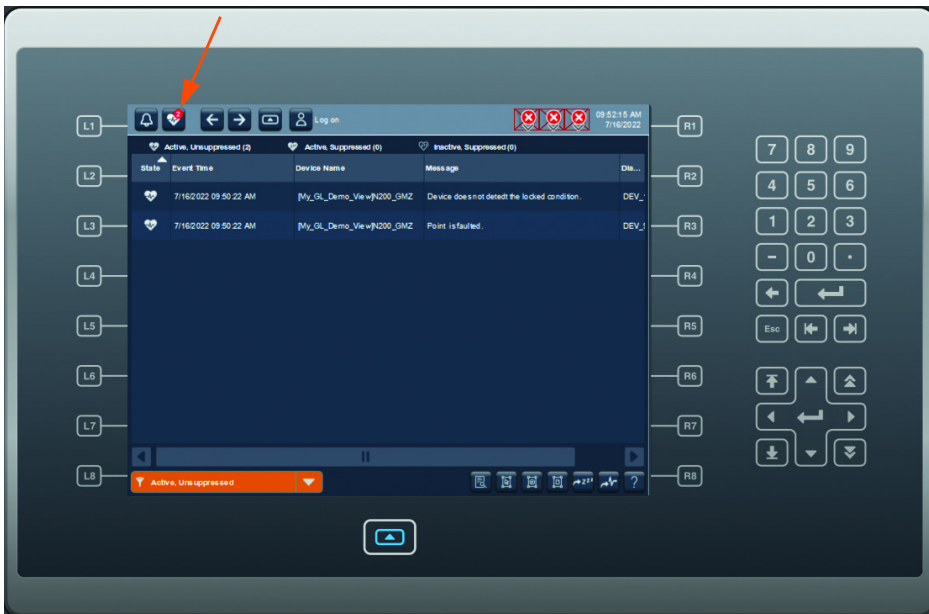

432ES-IG3 network interface modules, Bulletin 440S taps, and 440G-MZ safety switches have unique diagnostic codes that report automatically. See [Table 5...Table 7 on page 18](#).

Table 5 - 432ES-IG3 Network Interface Module Diagnostics

Display Code	Diagnostic Message
CH-FLT	Channel x is faulted.
M-HIPWR	The supply voltage exceeds a specified limit.
M-LOPWR	The supply voltage is below a specified limit.
M-IFLT	Device has internal fault.
CH-TFLT	Channel x has a terminator fault.
CH-DEVCNT	Channel x has too many devices.
CH-DEVUNV	Channel x has an unverified device.
PORT-FLT	Ethernet port is disconnected.
CONN_LOSS	Connection lost with device.

Table 6 - Bulletin 440S Tap Automatic Diagnostics

Display Code	Diagnostic Message
PT-FLT	Point x is faulted.
M-HIPWR	The supply voltage exceeds a specified limit.
M-LOPWR	The supply voltage is below a specified limit.
M-IFLT	Device has internal fault.
M-SHCI	Device has a short circuit or overcurrent condition.
M-DSCFLT	Device has an input channel discrepancy.
M-SIGFLT	Device has an invalid GuardLink® signal.
CONN_LOSS	Connection lost with device.

Table 7 - 440G-MZ Safety Switch Diagnostics

Display Code	Diagnostic Message
PT-FLT	Point x is faulted.
M-HIPWR	The supply voltage exceeds a specified limit.
M-LOPWR	The supply voltage is below a specified limit.
M-IFLT	Device has internal fault.
M-SHCI	Device has a short circuit or overcurrent condition.
M-ACTFLT	Device detects an invalid actuator.
M-ACTLIM	Device cannot teach new actuator because teach limit has been reached.
M-ACTTCH	Device actuator teach process is incomplete.
M-LCKDET	Device does not detect the locked condition.
M-LCKFLT	Device is unable to lock or unlock as commanded.
M-ACTNDT	Device does not detect the actuator closed position.
M-OTMP	Device has an over-temperature condition.
M-UTMP	Device has an under-temperature condition.
M-DSCFLT	Device has an input channel discrepancy.
M-ACTNPR	Device has not been paired with an actuator.
M-SIGFLT	Device has an invalid GuardLink signal.
CONN_LOSS	Connection lost with device.

Automatic Diagnostics on FactoryTalk View SE

IMPORTANT Verify that FactoryTalk Alarms and Events is installed and configured before attempting to view automatic diagnostics. For more information, see publication [FTAE-RM001](#).

You can use the Subscribe To setting under FactoryTalk Alarms and Events in FactoryTalk Linx to activate or deactivate diagnostic information that is sent to the Automatic Diagnostics Event Summary object.

Subscribe To

- To adjust your automatic diagnostics, access the Communication setup and select your device.

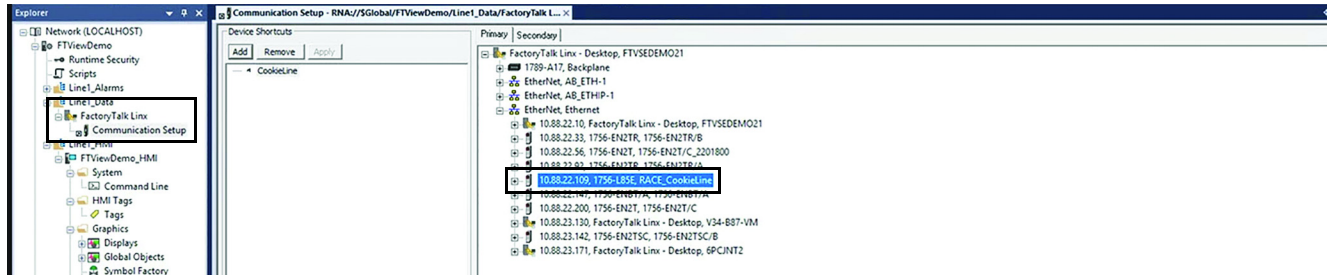

- To receive all notifications from your devices, set the Subscribe To setting to All Alarms & Events Notification Messages.

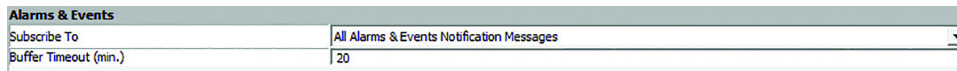

If the Subscribe To is set to Only Alarms Notification Messages, then the Automatic Diagnostics Event Summary object is blank.

View Automatic Diagnostic Messages

IMPORTANT After Logix version 33 release, any device can participate in automatic diagnostics with an AOP update.

Events are delivered through FactoryTalk® Alarms and Events (FTAE) with FactoryTalk View Site Edition (SE) v12 and greater as a Display Client™.

Figure 8 - FTView SE v12.0 Automatic Diagnostics Example

State	Ass...	Event Time	Area	Device Name	Catalog	Product Type	Message
		<all>	<all>	<all>	<all>	<all>	<all>
		4/13/2020 10:16:17 AM	[AD_Demo]Remote_DLR	1756-EN2TR	Communications Adapter	Communications Adapter	Connection Lost with Device
		4/13/2020 10:16:22 AM	[AD_Demo]JOB16D	1756-OB16D/A	General Purpose Discrete I/O	General Purpose Discrete I/O	Point 1, No Load - The wire is disconnected from the module.
		4/13/2020 10:16:22 AM	[AD_Demo]JOB16D	1756-OB16D/A	General Purpose Discrete I/O	General Purpose Discrete I/O	Point 2, No Load - The wire is disconnected from the module.
		4/13/2020 10:16:22 AM	[AD_Demo]JOB16D	1756-OB16D/A	General Purpose Discrete I/O	General Purpose Discrete I/O	Point 4, No Load - The wire is disconnected from the module.
		4/13/2020 10:16:22 AM	[AD_Demo]JOB16D	1756-OB16D/A	General Purpose Discrete I/O	General Purpose Discrete I/O	Point 9, No Load - The wire is disconnected from the module.
		4/13/2020 10:16:22 AM	[AD_Demo]JOB16D	1756-OB16D/A	General Purpose Discrete I/O	General Purpose Discrete I/O	Point 10, No Load - The wire is disconnected from the module.
		4/13/2020 10:16:22 AM	[AD_Demo]JOB16D	1756-OB16D/A	General Purpose Discrete I/O	General Purpose Discrete I/O	Point 12, No Load - The wire is disconnected from the module.
		4/13/2020 10:16:22 AM	[AD_Demo]JOB16D	1756-OB16D/A	General Purpose Discrete I/O	General Purpose Discrete I/O	Point 14, No Load - The wire is disconnected from the module.
		4/13/2020 10:16:22 AM	[AD_Demo]JOB16D	1756-OB16D/A	General Purpose Discrete I/O	General Purpose Discrete I/O	Point 15, No Load - The wire is disconnected from the module.
		4/13/2020 10:21:36 AM	[AD_Demo]AutomaticDiagnostics_v33_Demo	1756-L85E	Programmable Logic Controller	ajor Fault T04:C34 - Program Fault: A timer instruction had a negative value for its PRE or ACC	

To view these diagnostic messages, you need:

- FactoryTalk Alarms and Events, version 6.20 and greater
- FactoryTalk View SE, version 12 and greater

Automatic diagnostics are enabled by default. Check the configuration of your device to see whether the firmware supports automatic diagnostics.

Automatic Diagnostics History

FactoryTalk Alarms and Events (FTAE) keeps a historical log all Automatic Diagnostics activity. The historical log is stored in the same SQL database as the FTAE alarms. FTLine must be configured to log alarm and event historical information into the SQL database. In the FTView SE application, the historical log is viewed using the data grid control. From the data grid, you can export to CSV.

Message	ServerName	State	Catalog	MajorRev	MinorRev	EventType	SourcePath	MessageCode
Connection Lost with Device	FactoryTalk L...	1	1756-IA16/A	3	1	2	RNA://SGlobal...	
Minor Fault T04:C06 - Program Fault: GSV/SSV operand invalid.	FactoryTalk L...	1	1756-L85E	33	11	2	RNA://SGlobal...	
Connection to controller is normal.	FactoryTalk L...	0		0	0	2	RNA://SGlobal...	
Connection to controller is normal.	FactoryTalk L...	0		0	0	2	RNA://SGlobal...	
Connection to controller has been lost.	FactoryTalk L...	1	1756-L85E	33	11	2	RNA://SGlobal...	
Connection to controller is normal.	FactoryTalk L...	0	1756-L85E	33	11	2	RNA://SGlobal...	
Connection to controller has been lost.	FactoryTalk L...	1	1756-L85E	33	11	2	RNA://SGlobal...	
Connection to controller is normal.	FactoryTalk L...	0	1756-L85E	33	11	2	RNA://SGlobal...	

Online Updates of Device Additional Diagnostics

- Additional device diagnostics are distributed with updated AOPs
- These additional device diagnostics can be added while online to a running controller
- You are notified that updates are available in the following ways:
 - Project verification warning

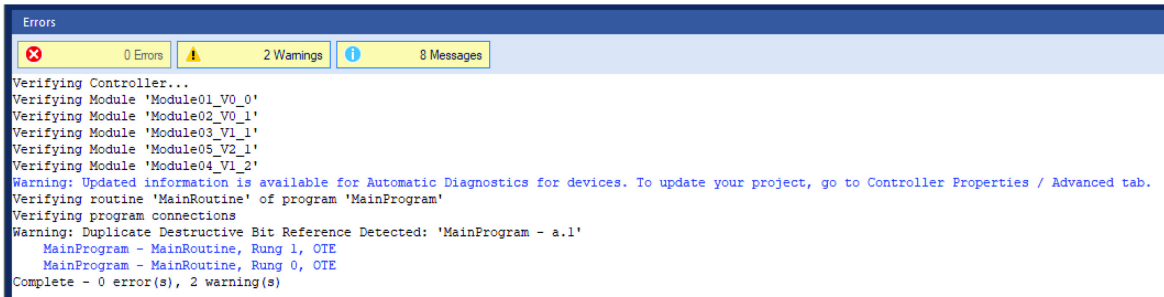

```

Errors
0 Errors 2 Warnings 8 Messages

Verifying Controller...
Verifying Module 'Module01_V0_0'
Verifying Module 'Module02_V0_1'
Verifying Module 'Module03_V1_1'
Verifying Module 'Module05_V2_1'
Verifying Module 'Module04_V1_2'
Warning: Updated information is available for Automatic Diagnostics for devices. To update your project, go to Controller Properties / Advanced tab.
Verifying routine 'MainRoutine' of program 'MainProgram'
Verifying program connections
Warning: Duplicate Destructive Bit Reference Detected: 'MainProgram - a.1'
      MainProgram - MainRoutine, Rung 1, OIE
      MainProgram - MainRoutine, Rung 0, OIE
Complete - 0 error(s), 2 warning(s)
  
```

- Information message in the controller Properties (Advanced tab)

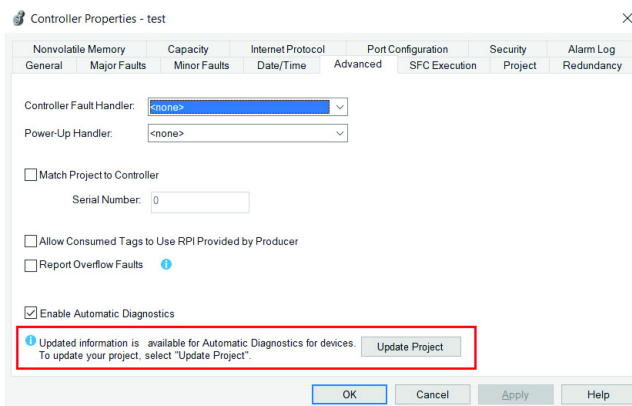

Additional diagnostics can be downloaded to the controller by pressing the Update Project button.

SISTEMA

SISTEMA is a free program that is used to determine the safety function values per ISO 13849. Many devices are preloaded into a Rockwell Automation library. The 432ES network interface, DG safety relay, and taps were loaded into a local library based on the tap ratings (see publication [440R-UM015](#)). These devices will be available in a future update of the Rockwell Automation library.

[Figure 9](#) shows the first two safety functions. To generate the remaining functions, you can simply copy and paste these functions back into the project and then change the input device.

To achieve a PLe rating and a 20-year mission time, the system is limited to 65,000 operations each year. The limiting component is the 100S contactors, which are driving the motor load. The E-stop has a limitation of 12,000 operations per year.

Figure 9 - SISTEMA Project - First Two Safety Functions

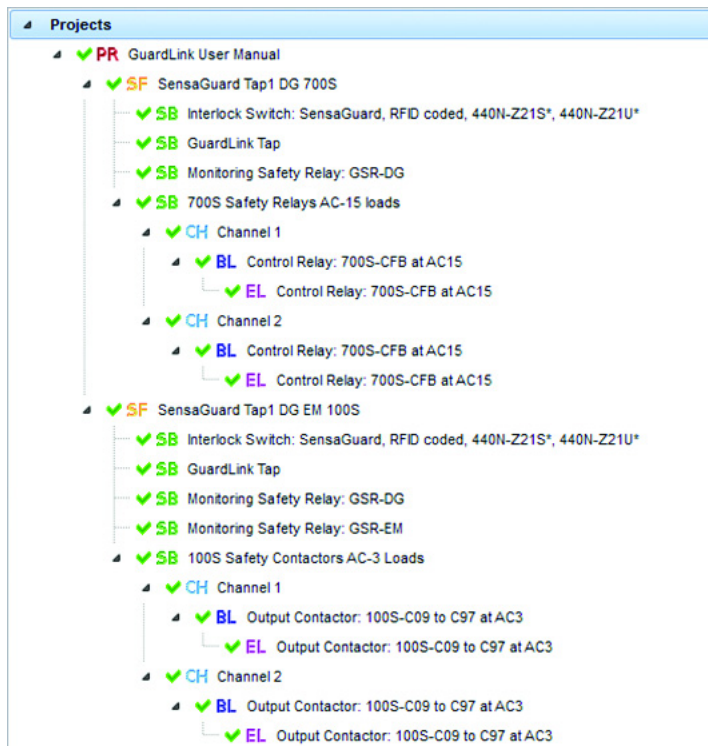

[Figure 10](#) shows a summary of the project. Each safety function has a required Performance Level of 'e', and each safety function has achieved that level.

Figure 10 - Project Summary

The screenshot shows the 'SISTEMA Project' window with the 'Safety functions' tab selected. On the left, there are buttons for 'New', 'Edit', and 'Delete'. The main area contains a table with the following data:

Status	Name	Type	PLr	PL
✓ SF	SensaGuard Tap1 DG 700S		e	e
✓ SF	SensaGuard Tap1 DG EM 100S		e	e
✓ SF	440G-LZ Tap2 DG 700S		e	e
✓ SF	440G-LZ Tap2 DG EM 100S		e	e
✓ SF	E-stop Tap3 DG 700S		e	e
✓ SF	E-stop Tap3 DG EM 100S		e	e
✓ SF	LightCurtain Tap4 DG 700S		e	e
✓ SF	Light Curtain Tap4 DG EM 100S		e	e

Notes:

Additional Resources

These documents contain additional information concerning related products from Rockwell Automation. You can view or download publications at rok.auto/literature.

Resource	Description
GuardLink EtherNet/IP Network Interface User Manual, publication 432ES-UM001	Provides a detailed description of the GuardLink system when connected to the DG safety relay.
GuardLink EtherNet/IP Network Interface Installation Instructions, publication 432ES-IN001	Describes how to install a 432ES-IG3 network interface module.
Guardmaster DG Safety Relay and GuardLink System User Manual, publication 440R-UM015	Provides a detailed description of the GuardLink system when connected to the DG safety relay.
GuardLink Enabled Tap Installation Instructions, publication 440S-IN007	Describes how to install a 440S GuardLink-enabled tap.
GuardLink Passive Tap Installation Instructions, publication 440S-IN008	Describes how to install a 440S-PF5D passive tap.
GuardLink Passive Power Tap Installation Instructions, publication 440S-IN009	Describes how to install a 440S-PF5D4 passive power tap.
440G-MZ Guardmaster Guard Locking Switch User Manual, publication 440G-UM004	Provides general guidelines to install a 440G guard locking switch.
440G-MZ Guardmaster Safety Switches Installation Instructions, publication 440G-IN018	Describes how to install a 440G safety switch.
EtherNet/IP Network Devices User Manual, ENET-UM006	Describes how to configure and use EtherNet/IP devices to communicate on the EtherNet/IP network.
Ethernet Reference Manual, ENET-RM002	Describes basic Ethernet concepts, infrastructure components, and infrastructure features.
System Security Design Guidelines Reference Manual, SECURE-RM001	Provides guidance on how to conduct security assessments, implement Rockwell Automation products in a secure system, harden the control system, manage user access, and dispose of equipment.
UL Standards Listing for Industrial Control Products, publication CMPNTS-SR002	Assists original equipment manufacturers (OEMs) with construction of panels, to help ensure that they conform to the requirements of Underwriters Laboratories.
American Standards, Configurations, and Ratings: Introduction to Motor Circuit Design, publication IC-AT001	Provides an overview of American motor circuit design based on methods that are outlined in the NEC.
Industrial Components Preventive Maintenance, Enclosures, and Contact Ratings Specifications, publication IC-TD002	Provides a quick reference tool for Allen-Bradley industrial automation controls and assemblies.
Safety Guidelines for the Application, Installation, and Maintenance of Solid-state Control, publication SGI-1.1	Designed to harmonize with NEMA Standards Publication No. ICS 1.1-1987 and provides general guidelines for the application, installation, and maintenance of solid-state control in the form of individual devices or packaged assemblies incorporating solid-state components.
Industrial Automation Wiring and Grounding Guidelines, publication 1770-4.1	Provides general guidelines for installing a Rockwell Automation industrial system.
Product Certifications website, rok.auto/certifications .	Provides declarations of conformity, certificates, and other certification details.

Rockwell Automation Support

Use these resources to access support information.

Technical Support Center	Find help with how-to videos, FAQs, chat, user forums, Knowledgebase, and product notification updates.	rok.auto/support
Local Technical Support Phone Numbers	Locate the telephone number for your country.	rok.auto/phonesupport
Technical Documentation Center	Quickly access and download technical specifications, installation instructions, and user manuals.	rok.auto/techdocs
Literature Library	Find installation instructions, manuals, brochures, and technical data publications.	rok.auto/literature
Product Compatibility and Download Center (PCDC)	Download firmware, associated files (such as AOP, EDS, and DTM), and access product release notes.	rok.auto/pcdc

Documentation Feedback

Your comments help us serve your documentation needs better. If you have any suggestions on how to improve our content, complete the form at rok.auto/docfeedback.





Allen-Bradley, Cadet, ControlLogix, Display Client, Elf, expanding human possibility, FactoryTalk, GuardLink, GuardLogix, Guardmaster, GuardShield, Integrated Architecture, Lifeline, On-Machine, PanelView, Rockwell Automation, Rotacam, SensaGuard, Slamlock, Studio 5000 View Designer, and Trojan are trademarks of Rockwell Automation, Inc.

CIP Safety and EtherNet/IP are trademarks of ODVA, Inc.

Trademarks not belonging to Rockwell Automation are property of their respective companies.

Rockwell Automation maintains current product environmental compliance information on its website at rok.auto/pec.

Rockwell Otomasyon Ticaret A.Ş. Kar Plaza İş Merkezi E Blok Kat:6 34752, İçerenköy, İstanbul, Tel: +90 (216) 5698400 EEE Yönetmeliğine Uygundur

Connect with us.    

rockwellautomation.com ————— expanding **human possibility**[®]

AMERICAS: Rockwell Automation, 1201 South Second Street, Milwaukee, WI 53204-2496 USA, Tel: (1) 414.382.2000, Fax: (1) 414.382.4444

EUROPE/MIDDLE EAST/AFRICA: Rockwell Automation NV, Pegasus Park, De Kleetlaan 12a, 1831 Diegem, Belgium, Tel: (32) 2663 0600, Fax: (32) 2 663 0640

ASIA PACIFIC: Rockwell Automation SEA Pte Ltd, 2 Corporation Road, #04-05, Main Lobby, Corporation Place, Singapore 618494, Tel: (65) 6510 6608, FAX: (65) 6510 6699

UNITED KINGDOM: Rockwell Automation Ltd., Pitfield, Kiln Farm, Milton Keynes, MK11 3DR, United Kingdom, Tel: (44)(1908) 838-800, Fax: (44)(1908) 261-917

Publication GLINK-AT001A-EN-P - July 2023

Copyright © 2023 Rockwell Automation, Inc. All rights reserved. Printed in the U.S.A.